

Drilling

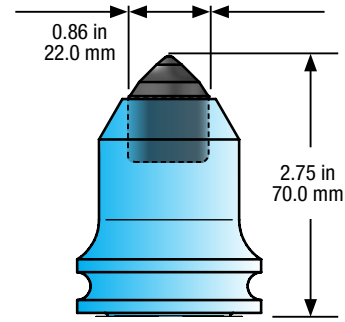

DX19
Carbide Plug

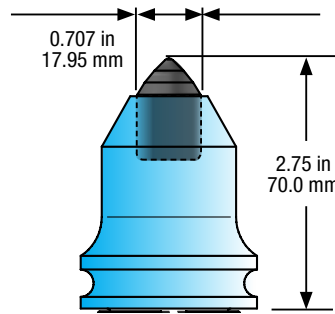

DX21
Carbide Plug

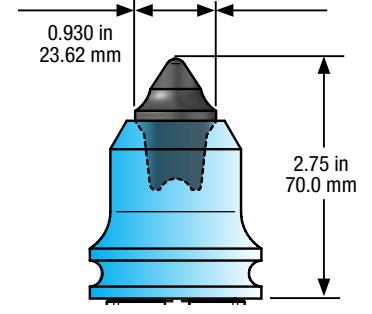

DX76
Carbide Hybrid

Features:

- Offered in Plugged tip, Hybrid tip and Large Cap tip for impact and highly abrasive material
- Offered with or without Puller groove for easy extraction
- Wide Shoulder tools offer maximum block, bore and seat protection

Tool Part Number	Shank (in, mm)	Shoulder (in, mm)	Tip Diameter (in, mm)	Gauge (in, mm)	Pieces per Box	Pieces per Pallet
DX19	1.5 in 30.0 mm	1.96 in 49.7 mm	0.86 in 22.0 mm	2.75 in 70.0 mm	10	600
DX21	1.5 in 30.0 mm	1.96 in 49.7 mm	0.707 in 17.95 mm	2.75 in 70.0 mm	10	600
DX76	1.5 in 30.0 mm	1.96 in 49.7 mm	0.930 in 23.62 mm	2.75 in 70.0 mm	10	600

Block Part Number	Bore Hole Diameter (in, mm)	Width (in, mm)	Angle (degrees)	Internal Groove	Pieces per Box	Pieces per Pallet
B38H45	1.50 in 38.2 mm	2.62 in 66.5 mm	45°	Yes	8	480
B38R	1.50 in 38.1 mm	2.99 in 76.0 mm	N/A	Yes	15	900

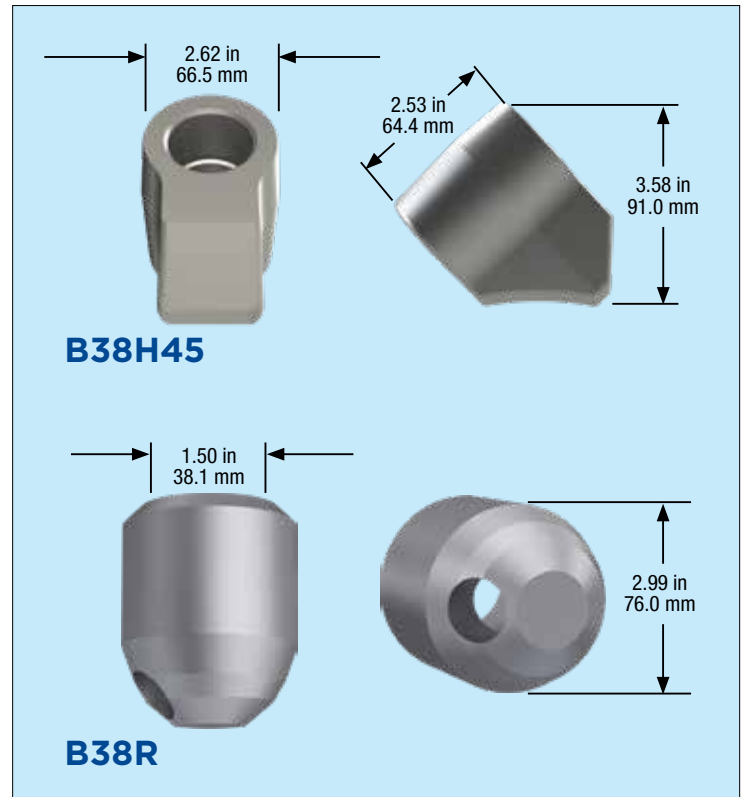

B38H45

B38R



Proudly made in the U.S.A.

Drilling



Features:

- Offered in Plugged tip, Hybrid tip and Large Cap tip for impact and highly abrasive material
- Offered with or without Puller groove for easy extraction
- Wide Shoulder tools offer maximum block, bore and seat protection

Tool Part Number	Shank (in, mm)	Shoulder (in, mm)	Tip Diameter (in, mm)	Gauge (in, mm)	Pieces per Box	Pieces per Pallet
DXW20	1.5 in 30.0 mm	2.5 in 64.0 mm	1.30 in 33.02 mm	2.5 in 64.0 mm	10	600
DXW21	1.5 in 30.0 mm	2.5 in 64.0 mm	0.707 in 17.95 mm	2.75 in 70.0 mm	10	600
DXW76	1.5 in 30.0 mm	2.5 in 64.0 mm	0.817 in 20.75 mm	2.75 in 70.0 mm	10	600

Block Part Number	Bore Hole Diameter (in, mm)	Width (in, mm)	Angle (degrees)	Internal Groove	Pieces per Box	Pieces per Pallet
B38H45	1.50 in 38.2 mm	2.62 in 66.5 mm	45°	Yes	8	480
B38R	1.50 in 38.1 mm	2.99 in 76.0 mm	N/A	Yes	15	900

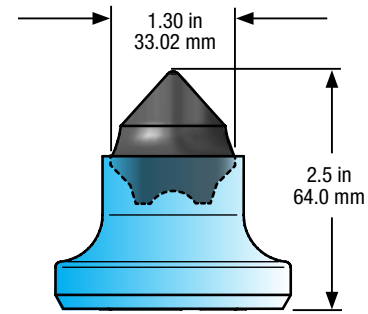

DXW20
Valve Seat

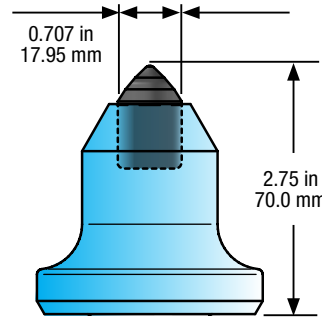

DXW21
Carbide Plug

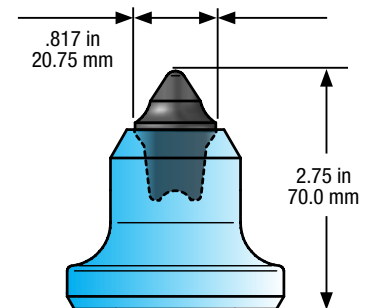

DXW76
Carbide Hybrid
(Plug/Valve Seat)

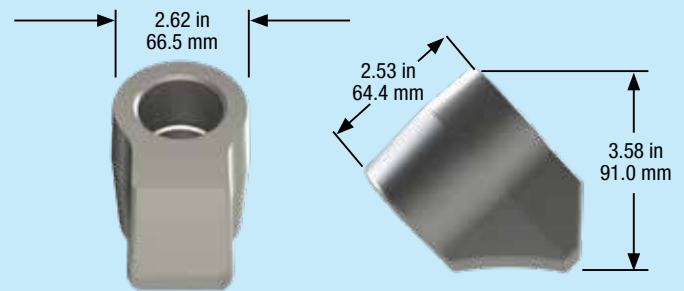

B38H45

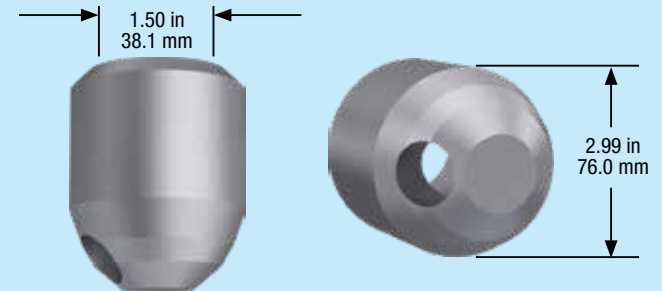

B38R



Proudly made in the U.S.A.

Drilling

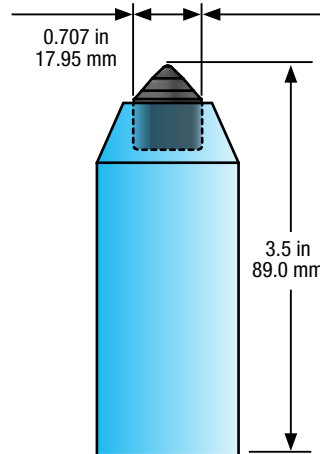

DXL08K
Carbide Plug

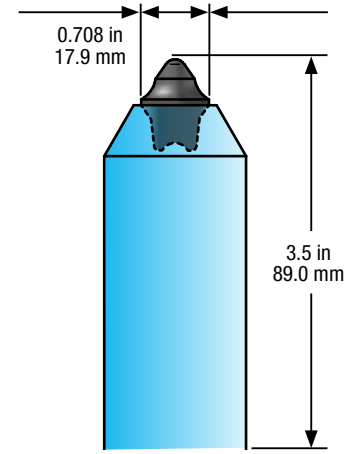

DXL74K
Carbide Hybrid
(Plug/Valve Seat)

Features:

- Unique tool design provides superior penetration
- Offered in both Plugged tip or Hybrid tip for impact and highly abrasive material
- Utilizes Sleeve and/or Snap ring retainer to maintain maximum block bore and seat protection
- Offered with or without Puller groove for easy extraction

Tool Part Number	Shank (in, mm)	Shoulder (in, mm)	Tip Diameter (in, mm)	Gauge (in, mm)	Pieces per Box	Pieces per Pallet
DXL08K	1.5 in 30.0 mm	NA	0.707 in 17.95 mm	3.5 in 89.0 mm	10	600
DXL74K	1.5 in 30.0 mm	NA	0.708 in 17.9 mm	3.5 in 89.0 mm	10	600

Block Part Number	Bore Hole Diameter (in, mm)	Width (in, mm)	Angle (degrees)	Internal Groove	Pieces per Box	Pieces per Pallet
B38H45	1.50 in 38.2 mm	2.62 in 66.5 mm	45°	Yes	8	480
B38R	1.50 in 38.1 mm	2.99 in 76.0 mm	N/A	Yes	15	900

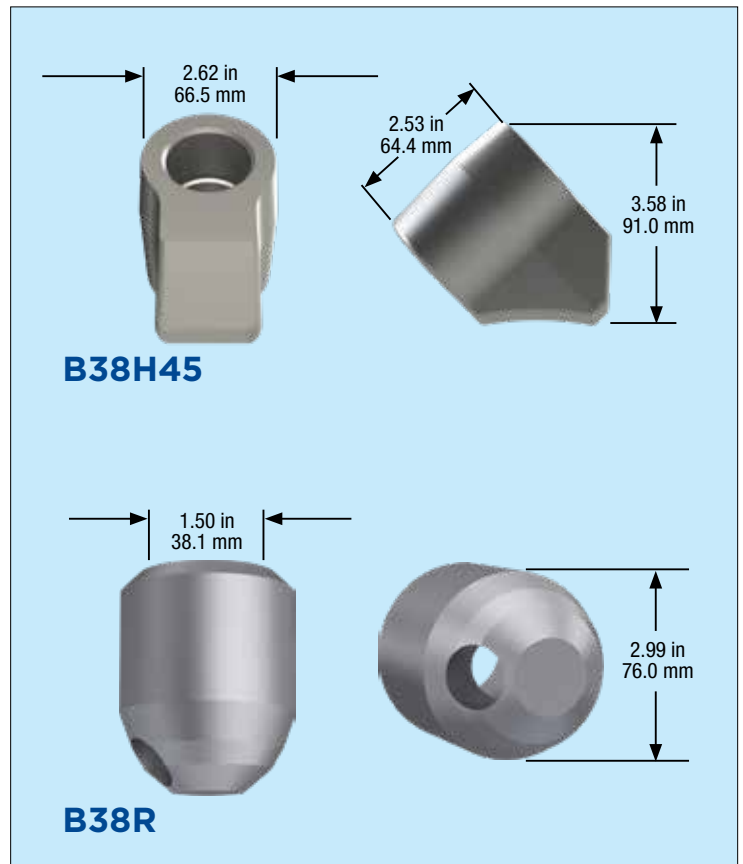

Proudly made in the U.S.A.