

Drilling

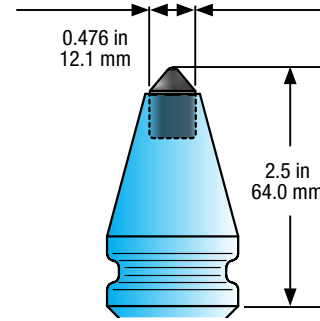

Detailed view of carbide tip



DR35
Carbide Plug

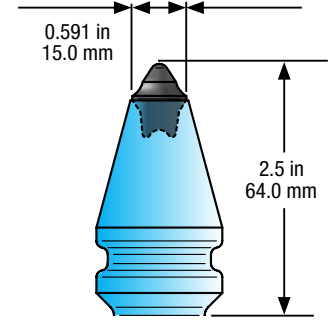

DR73
Carbide Hybrid
(Plug/Valve Seat)

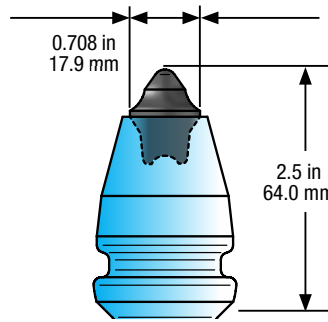

DR74
Carbide Hybrid
(Plug/Valve Seat)

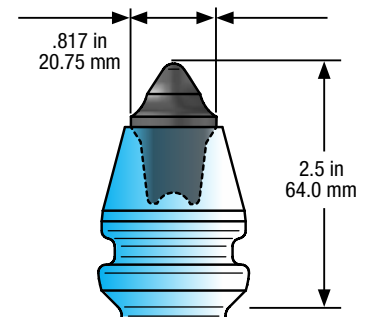

DR75
Carbide Hybrid
(Plug/Valve Seat)

Features:

- Sharp nose for increased penetration
- Offered in a Hybrid tip, or Plug tip for impact and highly abrasive material
- Interchangeable series offers flexibly

Tool Part Number	Shank (in, mm)	Shoulder (in, mm)	Tip Diameter (in, mm)	Gauge (in, mm)	Pieces per Box	Pieces per Pallet
DR35	1.0 in 25.0 mm	1.5 in 38.1 mm	0.476 in 12.1 mm	2.5 in 64.0 mm	35	2100
DR73	1.0 in 25.0 mm	1.5 in 38.1 mm	0.591 in 15.0 mm	2.5 in 64.0 mm	35	2100
DR74	1.0 in 25.0 mm	1.5 in 38.1 mm	0.708 in 17.9 mm	2.5 in 64.0 mm	35	2100
DR75	1.0 in 25.0 mm	1.5 in 38.1 mm	.817 in 20.75 mm	2.5 in 64.0 mm	35	2100

Block Part Number	Bore Hole Diameter (in, mm)	Width (in, mm)	Angle (degrees)	Internal Groove	Pieces per Box	Pieces per Pallet
B25HN45	1.012 in 25.71 mm	1.72 in 43.7 mm	45°	Yes	15	900
B25H45	1.012 in 25.71 mm	1.969 in 50.0 mm	45°	Yes	8	480

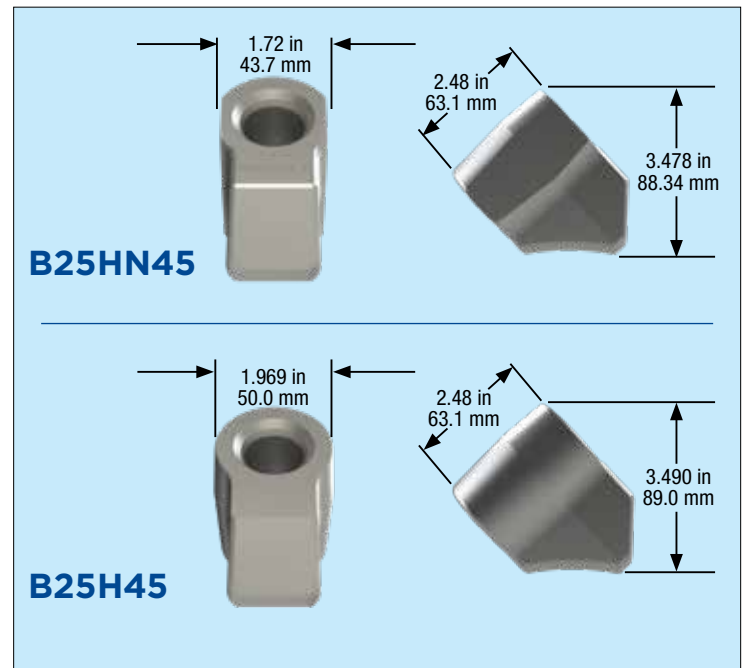

Proudly made in the U.S.A.

Drilling



Features:

- Wide-flare shoulder provides maximum block and bore protection
- Offered in a Hybrid tip or Wide-Top tip for impact and highly abrasive material
- Interchangeable series offers flexibility

Tool Part Number	Shank (in, mm)	Shoulder (in, mm)	Tip Diameter (in, mm)	Gauge (in, mm)	Pieces per Box	Pieces per Pallet
DRW73	1.0 in 25.0 mm	1.84 in 46.7 mm	0.591 in 15.0 mm	2.50 in 64.0 mm	30	1800
DRW74	1.0 in 25.0 mm	1.84 in 46.7 mm	.708 in 17.98 mm	2.50 in 64.0 mm	30	1800
DRW75	1.0 in 25.0 mm	1.84 in 46.7 mm	.817 in 20.75 mm	2.50 in 64.0 mm	30	1800
DRW76	1.0 in 25.0 mm	1.84 in 46.7 mm	0.930 in 23.62 mm	2.50 in 64.0 mm	30	1800

Block Part Number	Bore Hole Diameter (in, mm)	Width (in, mm)	Angle (degrees)	Internal Groove	Pieces per Box	Pieces per Pallet
B25HN45	1.012 in 25.71 mm	1.72 in 43.7 mm	45°	Yes	15	900
B25H45	1.012 in 25.71 mm	1.969 in 50.0 mm	45°	Yes	8	480

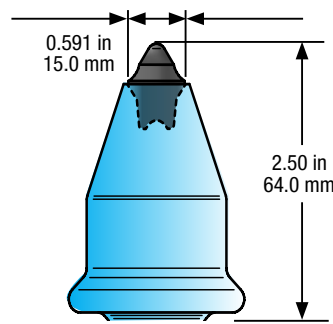

DRW73
Carbide Hybrid
(Plug/Valve Seat)

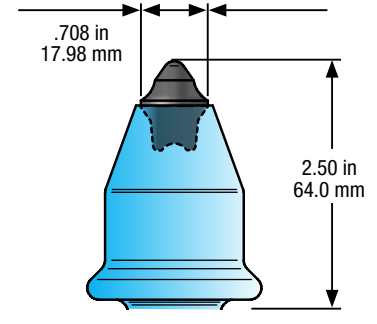

DRW74
Carbide Hybrid
(Plug/Valve Seat)

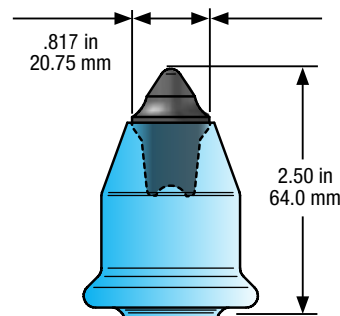

DRW75
Carbide Hybrid
(Plug/Valve Seat)

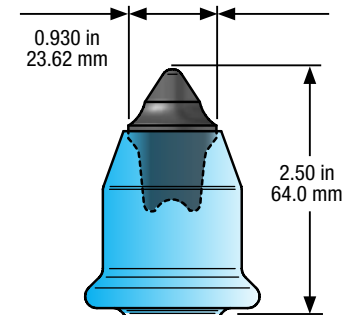

DRW76
Carbide Hybrid
(Plug/Valve Seat)

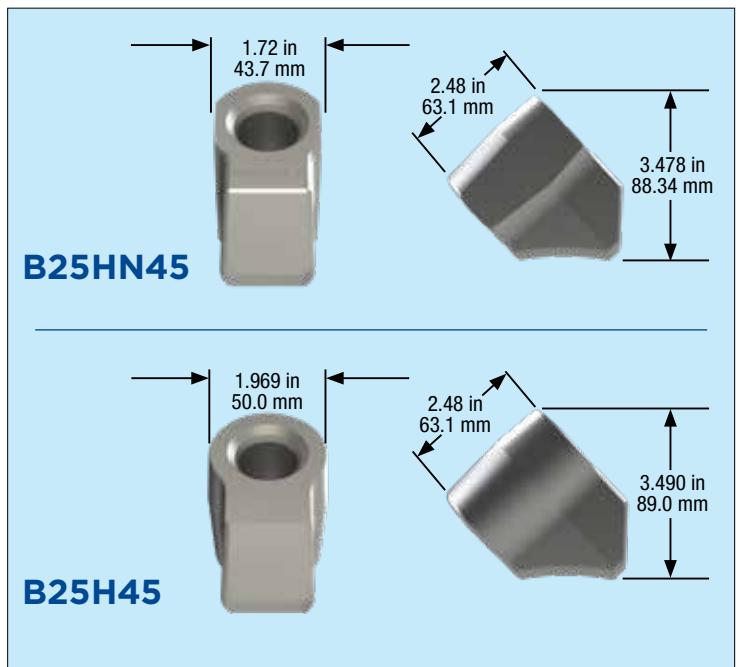

Proudly made in the U.S.A.