



**XCAL**  
TOOLS



## TRENCHING

## Locations and Sales Contacts

---

### **XCAL TOOLS of Clare**

314 E. 4th Street  
Clare, MI 48617  
Ph: (989) 386-5376

---

### **XCAL TOOLS of Madisonville**

3957 Anton Road  
Madisonville, KY 42431  
Ph: (270) 825-BITS (2487)

---

### **XCAL TOOLS of South Point**

235 Commerce Drive  
South Point, OH 45680  
Ph: (740) 377-3354  
Fax: (740) 377-3363

---

### **XCAL Industries**

843 Lochgelly Road  
Oak Hill, WV 25901  
Ph: (304) 469-4721  
Fax: (304) 469-4750

---

### **XCAL TOOLS of Beckley**

256 Industrial Drive  
Oak Hill, WV 25901  
Ph: (304) 465-0651  
Fax: (304) 465-5244

---

### **XCAL TOOLS of Bristol**

15020 Industrial Park Road  
Bristol, VA 24202  
Ph: (276) 644-3520  
Fax: (276) 644-3523





## SUPERIOR QUALITY

XCAL TOOLS takes pride in manufacturing and selling a full line of road planing, soil stabilization, reclaiming, grading, trenching and foundation drilling bits and carbide tooling products that are American-made. Our inhouse operations gives us the flexibility to quickly test and adapt to changing environments and customer needs. Our cost effective production methods, allows us to provide a exceptional product of the highest quality.





## SERVICE AND INNOVATION

For over 20 years, our carbide producer XCAL INDUSTRIES, has been producing high quality carbide for the mining, roof drilling, snow and ice removal, road planing, wear products and metal cutting blanks, producing over fifty grades of cemented carbide and the capability to develop extra coarse, tougher grades to meet the demands of the industry.

These affiliates of JENMAR, in collaboration with each other, can provide you with superior quality products and unmatched customer service. Our commitment to the customer is guided by three words; SAFETY, SERVICE, and INNOVATION. It's these words that form the foundation of our business. It's who we are.



# Table of Contents

## TRENCHING

Carbide Tips .....	8
The Hybrid Difference .....	9
Accessories .....	26

## 18MM

TB01 .....	10
TB03 .....	10
TB73 .....	10
B18L45 .....	10
B18H45 .....	10
B18HT45 .....	10

## 19MM

TC403L .....	11
TC403 .....	11
TC473 .....	11
B19L45 .....	11
B19H45 .....	11
B19HT45 .....	11

## 22MM

TJ401 .....	12
TJ403 .....	12
TJ474 .....	12
TJ401L .....	13
TJ403L .....	13
TJ474L .....	13
TJ486L .....	13
B22NR45 .....	12-13
B22H45 .....	12-13
B22HT45 .....	12-13

## 25MM

DR35 .....	14
DR73 .....	14
DR74 .....	14
DR75 .....	14
DRW73 .....	15
DRW74 .....	15
DRW75 .....	15
DRW76 .....	15
TR74 .....	16
TR75 .....	16
TR76 .....	16
TRG74 .....	17

TRG75 .....	17
B25HN45 .....	14-17
B25H45 .....	14-17
B25H50S .....	16-17
B25H50L .....	16-17

## 38X30MM

TX23 .....	18
TX39 .....	18
TX74 .....	18
TX75 .....	18
TX76 .....	18
TXF20 .....	19
TXF39 .....	19
TXF56 .....	19
TXF74 .....	19
TXF74P .....	19
TXF75 .....	20
TXF76 .....	20
TXF78 .....	20
TXV74 .....	21
TXV74P .....	21
TXV75 .....	21
TXV76 .....	21
TXV78 .....	21
TX39K .....	22
TX75K .....	22
TX76K .....	22
TXF20K .....	23
TXF39K .....	23
TXF74K .....	23
TXF74KP .....	23
TXF75K .....	24
TXF76K .....	24
TXF78K .....	24
TXV74KP .....	25
TXV75K .....	25
TXV76K .....	25
TXV78K .....	25
B38H50S .....	20-24
B38H50L .....	20-24
B38HD50S .....	20-24
B38HD50L .....	20-24

## TAMCO TOOLS

Boom Mounted Demo Steel .....	27
-------------------------------	----

# Carbide Tips

We are an ISO 9001 certified facility that offers a wide range of carbide tips to match the various challenges that you might face. Producing over fifty grades of cemented carbide and the ability to create new ones, we can find a carbide grade to meet your needs. Our versatility helps us to check and respond easily to evolving conditions and customer needs. All of our tips provide superb penetration and maximum productivity - regardless of whether you work in soft, medium-hard or extremely hard and demanding conditions.



### Retainers Selection

Our retainer selection keeps tool changes quick and reduces your downtime



Proudly made in the U.S.A.

# The Hybrid Difference

XCAL TOOLS hybrid design gives you a blend of the efficient cutting characteristics of our CAP designs, combined with the durability and long life of a plug tip. Our design provides excellent penetration while retaining maximum strength, shear resistance and durability in challenging conditions, improves safety, efficiency and working conditions— leading to increased performance, productivity and lowered production costs.



## Cap Carbide Tips

For superior penetration: the larger carbide shoulder provides excellent protection against steel wash.

## Insert Carbide Tips

For high-impact conditions, or working with hard materials where steel wash is not an issue.

## The Hybrid Carbide Tip

The tapered bottom design provides more strength where it's needed most, helping to prevent carbide fracture.



### Cap Carbide Tips

Valve seat carbide tips are preferred over flat bottom tips providing a stronger bond between the carbide and steel giving more stability and support in highly abrasive conditions.



### Insert Carbide Tips

Insert carbide tips are best for penetration applications where steel wash is not an issue. These tips provide a strong bond between carbide and steel giving more stability and support proving ideal for use in hard, high-impact conditions.



### Hybrid Carbide Tips

Hybrid tips were developed for all cutting requirements - no matter how tough. You won't need to switch tools when your conditions change.



### Wide-Top Carbide Tips

Wide-Top tip combines the abrasive resistance of a cap tip with the impact resistance of a plug tip to maximise strength and steel support for ultimate durability in the most challenging conditions.



Proudly made in the U.S.A.



# Trenching



## Features:

- Standard body design
- Used for small Chain Trenchers and Rock Wheels
- Puller groove for easy tool removal
- Interchangeable series offers flexibly

Tool Part Number	Shank (in, mm)	Shoulder (in, mm)	Tip Diameter (in, mm)	Gauge (in, mm)	Pieces per Box	Pieces per Pallet
TB01	0.72 in 18.0 mm	1.0 in 25.4 mm	0.638 in 16.0 mm	1.79 in 45.0 mm	65	3900
TB03	0.72 in 18.0 mm	1.0 in 25.4 mm	0.476 in 12.1 mm	1.79 in 45.0 mm	65	3900
TB73	0.72 in 18.0 mm	1.0 in 25.4 mm	0.591 in 15.0 mm	1.79 in 45.0 mm	65	3900

Block Part Number	Bore Hole Diameter (in, mm)	Width (in, mm)	Angle (degrees)	Internal Groove	Pieces per Box	Pieces per Pallet
B18L45	.750 in 19.05 mm	1.375 in 34.9 mm	45°	Yes	35	2100
B18H45	.750 in 19.05 mm	1.625 in 41.28 mm	45°	Yes	35	2100
B18HT45	.750 in 19.05 mm	1.654 in 42.0 mm	45°	Yes	20	900

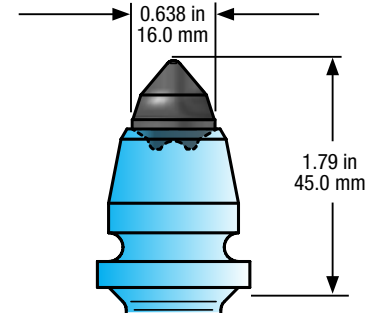

**TB01**  
Carbide Valve Seat Cap

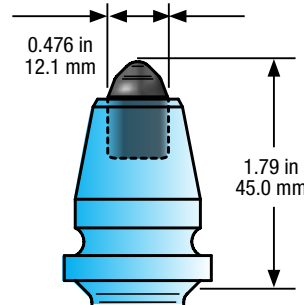

**TB03**  
Carbide Plug

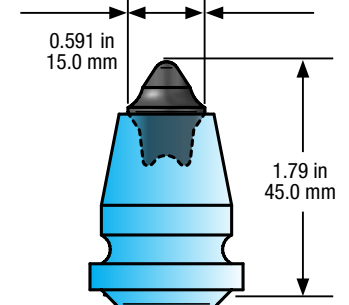

**TB73**  
Carbide Hybrid  
(Plug/Valve Seat)

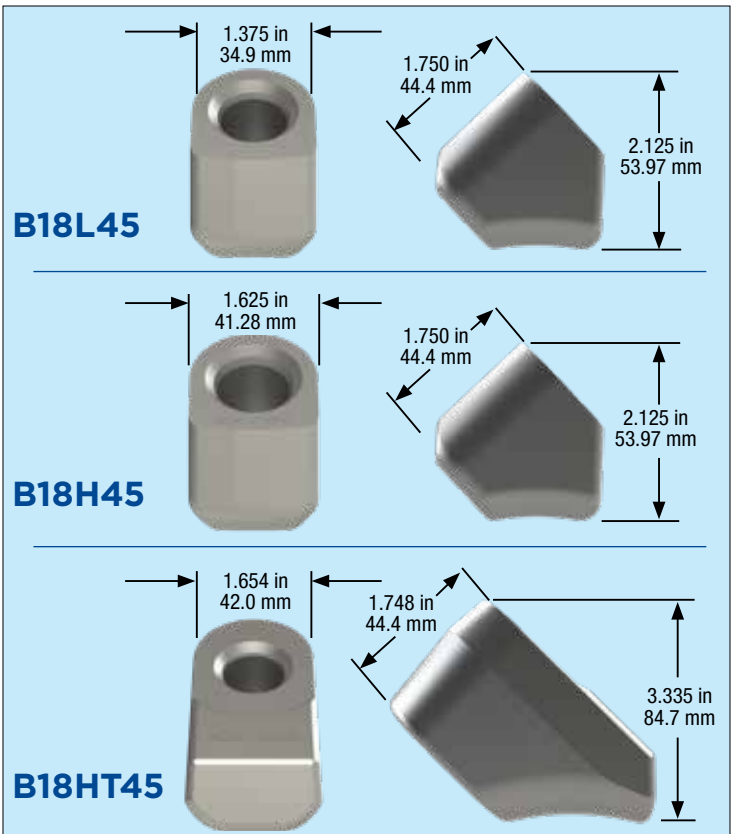

Proudly made in the U.S.A.

# Trenching

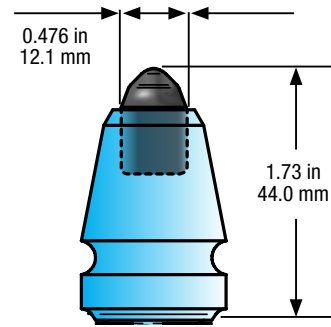

**TC403L**  
Carbide Plug

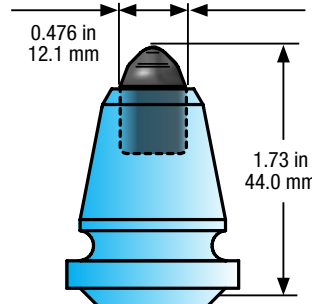

**TC403**  
Carbide Plug

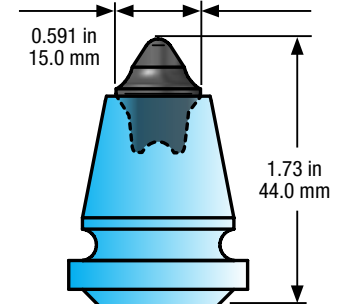

**TC473**  
Carbide Hybrid  
(Plug/Valve Seat)

## Features:

- Standard body design
- Used for small Chain Trenchers and Rock Wheels
- Puller groove for easy tool removal
- Offered with a Wedding Band or Sleeve retainer

Tool Part Number	Shank (in, mm)	Shoulder (in, mm)	Tip Diameter (in, mm)	Gauge (in, mm)	Pieces per Box	Pieces per Pallet
TC403L	0.74 in 19.0 mm	1.06 in 27.0 mm	0.476 in 12.1 mm	1.73 in 44.0 mm	65	3900
TC403	0.74 in 19.0 mm	1.25 in 31.75 mm	0.476 in 12.1 mm	1.73 in 44.0 mm	65	3900
TC473	0.74 in 19.0 mm	1.25 in 31.75 mm	0.591 in 15.0 mm	1.73 in 44.0 mm	65	3900

Block Part Number	Bore Hole Diameter (in, mm)	Width (in, mm)	Angle (degrees)	Internal Groove	Pieces per Box	Pieces per Pallet
B19L45	.782 in 19.87 mm	1.375 in 34.9 mm	45°	Yes	35	2100
B19H45	.782 in 19.87 mm	1.624 in 41.28 mm	45°	Yes	35	2100
B19HT45	.782 in 19.87 mm	1.654 in 42.0 mm	45°	Yes	20	900

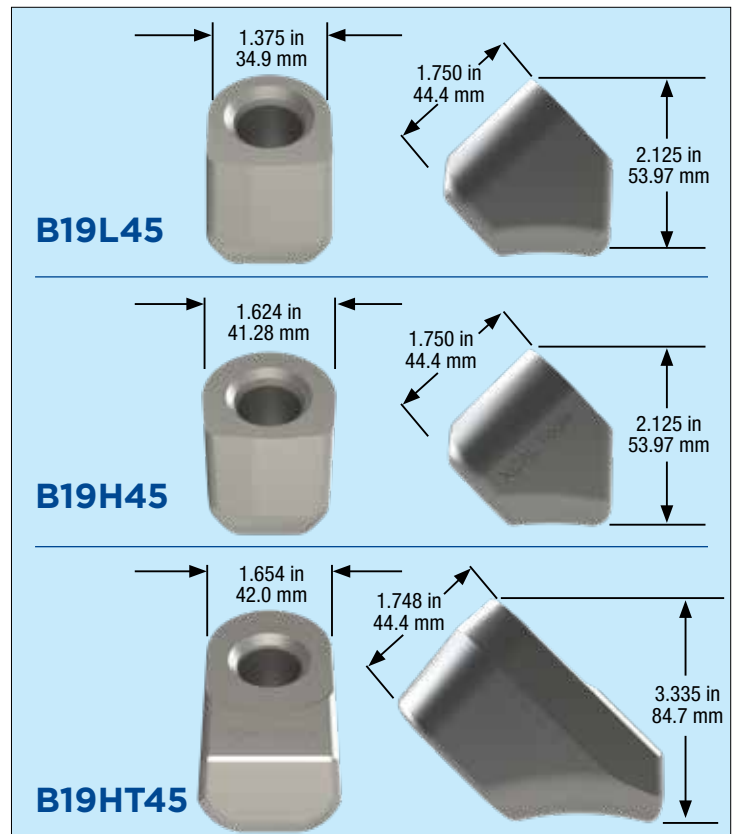

Proudly made in the U.S.A.

# Trenching

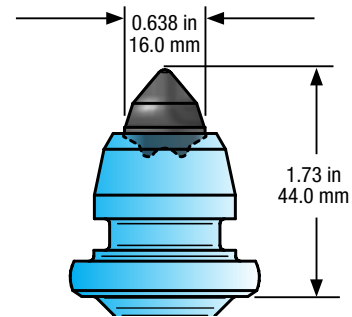

**TJ401**  
Carbide Valve Seat Cap

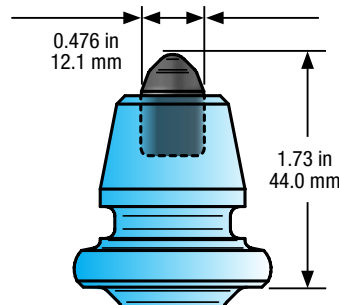

**TJ403**  
Carbide Plug

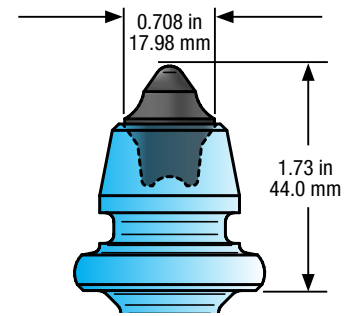

**TJ474**  
Carbide Hybrid  
(Plug/Valve Seat)

## Features:

- Bumped sleeve for improved retention
- Puller Groove to aid in extraction
- Interchangeable series offers flexibly

Tool Part Number	Shank (in, mm)	Shoulder (in, mm)	Tip Diameter (in, mm)	Gauge (in, mm)	Pieces per Box	Pieces per Pallet
TJ401	0.86 in 22.0 mm	1.5 in 38.1 mm	0.638 in 16.0 mm	1.73 in 44.0 mm	50	3000
TJ403	0.86 in 22.0 mm	1.5 in 38.1 mm	0.476 in 12.1 mm	1.73 in 44.0 mm	50	3000
TJ474	0.86 in 22.0 mm	1.5 in 38.1 mm	0.708 in 17.98 mm	1.73 in 44.0 mm	50	3000

Block Part Number	Bore Hole Diameter (in, mm)	Width (in, mm)	Angle (degrees)	Internal Groove	Pieces per Box	Pieces per Pallet
B22NR45	0.885 in 22.48 mm	1.512 in 38.4 mm	45°	Yes	35	2100
B22H45	0.885 in 22.48 mm	1.625 in 47.3 mm	45°	Yes	35	2100
B22HT45	0.885 in 22.48 mm	1.625 in 47.3 mm	45°	Yes	35	2100

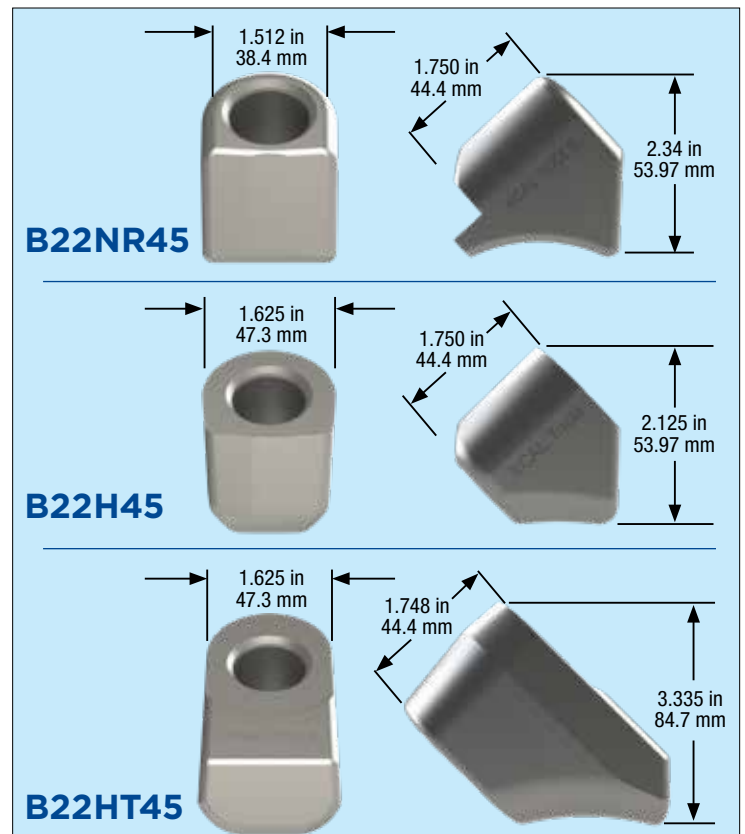

Proudly made in the U.S.A.

# Trenching

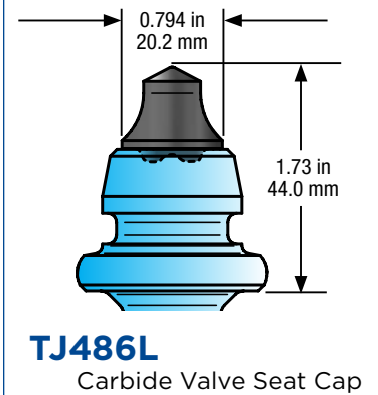
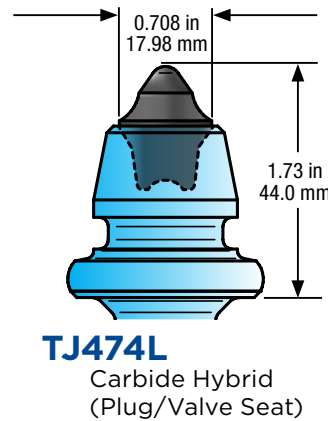
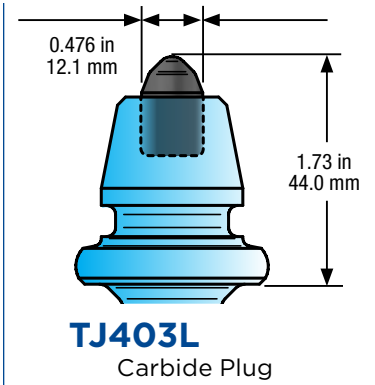
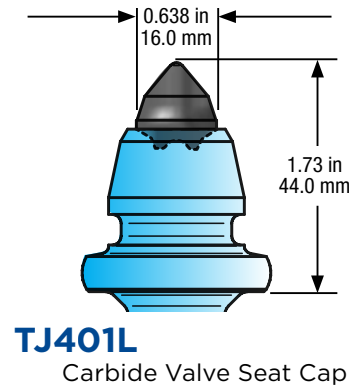

## Features:

- Offered in a wide range of tips for impact and highly abrasive material
- Puller Groove to aid in extraction
- Interchangeable series offers flexibility

Tool Part Number	Shank (in, mm)	Shoulder (in, mm)	Tip Diameter (in, mm)	Gauge (in, mm)	Pieces per Box	Pieces per Pallet
TJ401L	0.86 in 22.0 mm	1.5 in 38.1 mm	0.638 in 16.0 mm	1.73 in 44.0 mm	50	3000
TJ403L	0.86 in 22.0 mm	1.5 in 38.1 mm	0.476 in 12.1 mm	1.73 in 44.0 mm	50	3000
TJ474L	0.86 in 22.0 mm	1.5 in 38.1 mm	0.708 in 17.98 mm	1.73 in 44.0 mm	50	3000
TJ486L	0.86 in 22.0 mm	1.5 in 38.1 mm	0.794 in 20.2 mm	1.73 in 44.0 mm	50	3000

Block Part Number	Bore Hole Diameter (in, mm)	Width (in, mm)	Angle (degrees)	Internal Groove	Pieces per Box	Pieces per Pallet
B22NR45	0.885 in 22.48 mm	1.512 in 38.4 mm	45°	Yes	35	2100
B22H45	0.885 in 22.48 mm	1.625 in 47.3 mm	45°	Yes	35	2100
B22HT45	0.885 in 22.48 mm	1.625 in 47.3 mm	45°	Yes	35	2100

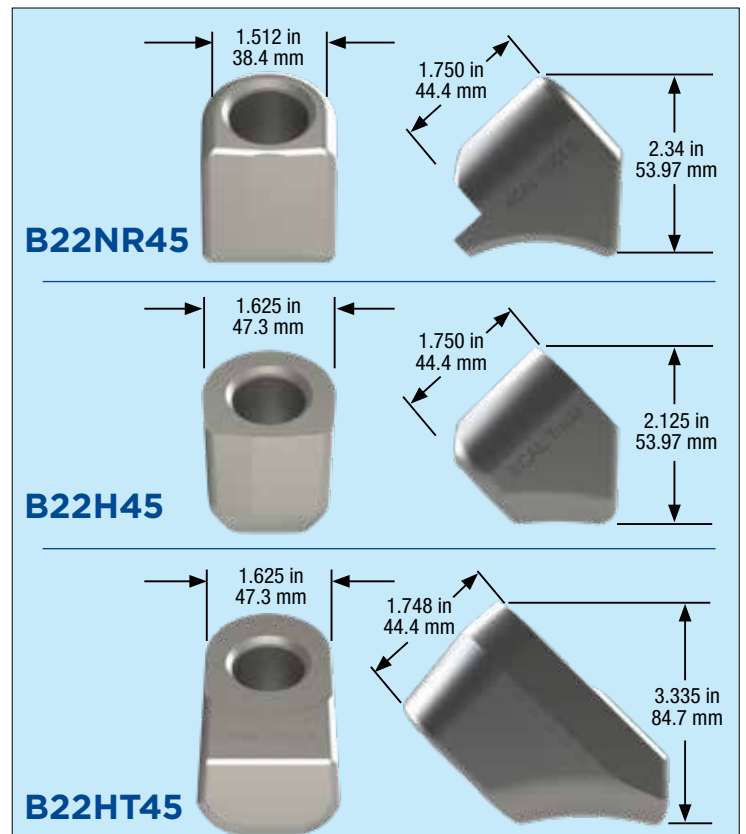

Proudly made in the U.S.A.

# Trenching



## Features:

- Sharp nose for increased penetration
- Offered in a Hybrid tip, or Plug tip for impact and highly abrasive material
- Interchangeable series offers flexibility

Tool Part Number	Shank (in, mm)	Shoulder (in, mm)	Tip Diameter (in, mm)	Gauge (in, mm)	Pieces per Box	Pieces per Pallet
DR35	1.0 in 25.0 mm	1.5 in 38.1 mm	0.476 in 12.1 mm	2.5 in 64.0 mm	35	2100
DR73	1.0 in 25.0 mm	1.5 in 38.1 mm	0.591 in 15.0 mm	2.5 in 64.0 mm	35	2100
DR74	1.0 in 25.0 mm	1.5 in 38.1 mm	0.708 in 17.9 mm	2.5 in 64.0 mm	35	2100
DR75	1.0 in 25.0 mm	1.5 in 38.1 mm	.817 in 20.75 mm	2.5 in 64.0 mm	35	2100

Block Part Number	Bore Hole Diameter (in, mm)	Width (in, mm)	Angle (degrees)	Internal Groove	Pieces per Box	Pieces per Pallet
B25HN45	1.012 in 25.71 mm	1.72 in 43.7 mm	45°	Yes	15	900
B25H45	1.012 in 25.71 mm	1.969 in 50.0 mm	45°	Yes	8	480

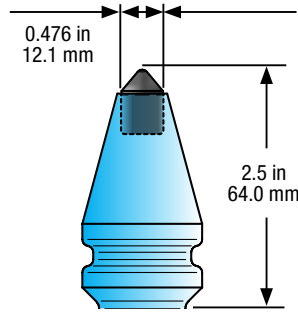

**DR35**  
Carbide Plug

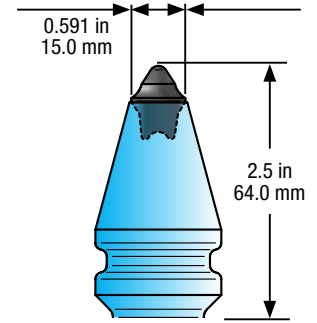

**DR73**  
Carbide Hybrid  
(Plug/Valve Seat)

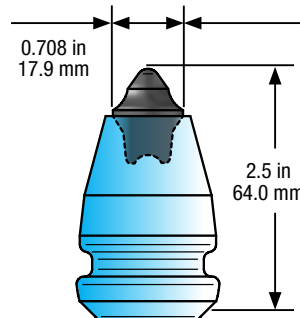

**DR74**  
Carbide Hybrid  
(Plug/Valve Seat)

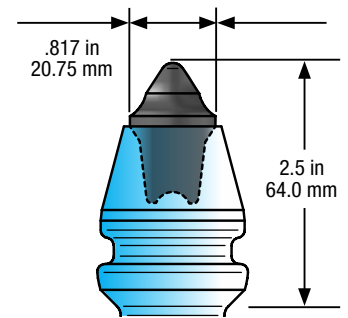

**DR75**  
Carbide Hybrid  
(Plug/Valve Seat)

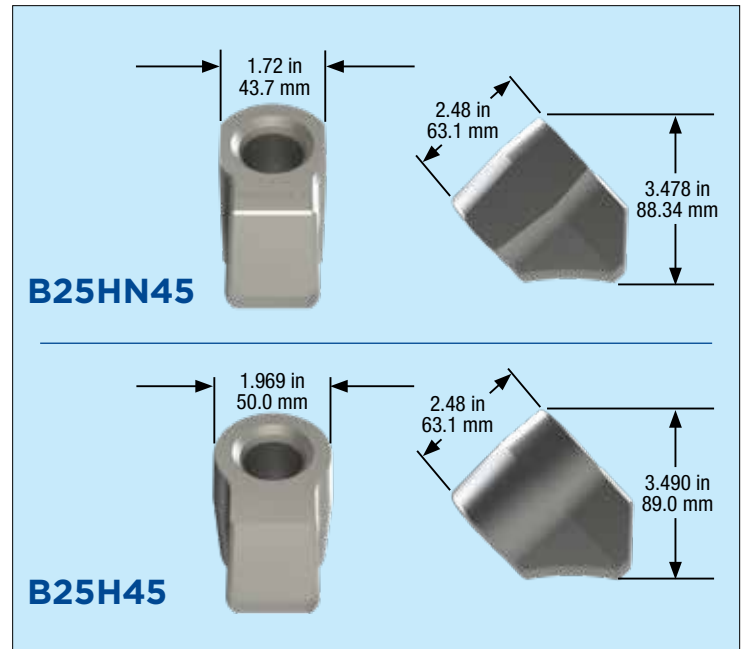

Proudly made in the U.S.A.

# Trenching



## Features:

- Wide-flare shoulder provides maximum block and bore protection
- Offered in a Hybrid tip or Wide-Top tip for impact and highly abrasive material
- Interchangeable series offers flexibility

Tool Part Number	Shank (in, mm)	Shoulder (in, mm)	Tip Diameter (in, mm)	Gauge (in, mm)	Pieces per Box	Pieces per Pallet
DRW73	1.0 in 25 mm	1.84 in 46.7 mm	0.591 in 15.0 mm	2.50 in 64.0 mm	25	1500
DRW74	1.0 in 25 mm	1.84 in 46.7 mm	.708 in 17.98 mm	2.50 in 64.0 mm	25	1500
DRW75	1.0 in 25 mm	1.84 in 46.7 mm	.817 in 20.75 mm	2.50 in 64.0 mm	25	1500
DRW76	1.0 in 25 mm	1.84 in 46.7 mm	0.930 in 23.62 mm	2.50 in 64.0 mm	25	1500

Block Part Number	Bore Hole Diameter (in, mm)	Width (in, mm)	Angle (degrees)	Internal Groove	Pieces per Box	Pieces per Pallet
B25HN45	1.012 in 25.71 mm	1.72 in 43.7 mm	45°	Yes	15	900
B25H45	1.012 in 25.71 mm	1.969 in 50.0 mm	45°	Yes	8	480

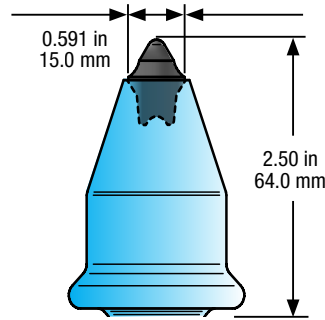

**DRW73**  
Carbide Hybrid  
(Plug/Valve Seat)

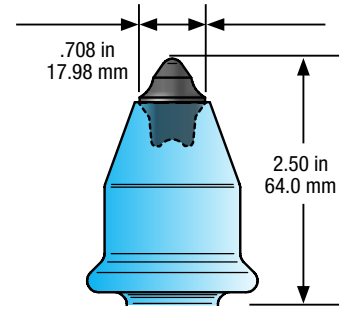

**DRW74**  
Carbide Hybrid  
(Plug/Valve Seat)

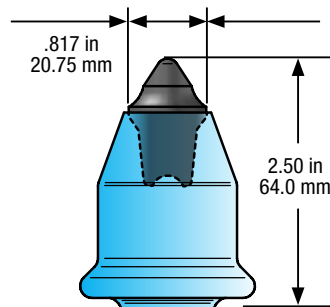

**DRW75**  
Carbide Hybrid  
(Plug/Valve Seat)

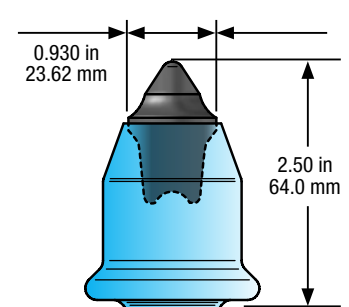

**DRW76**  
Carbide Hybrid  
(Plug/Valve Seat)

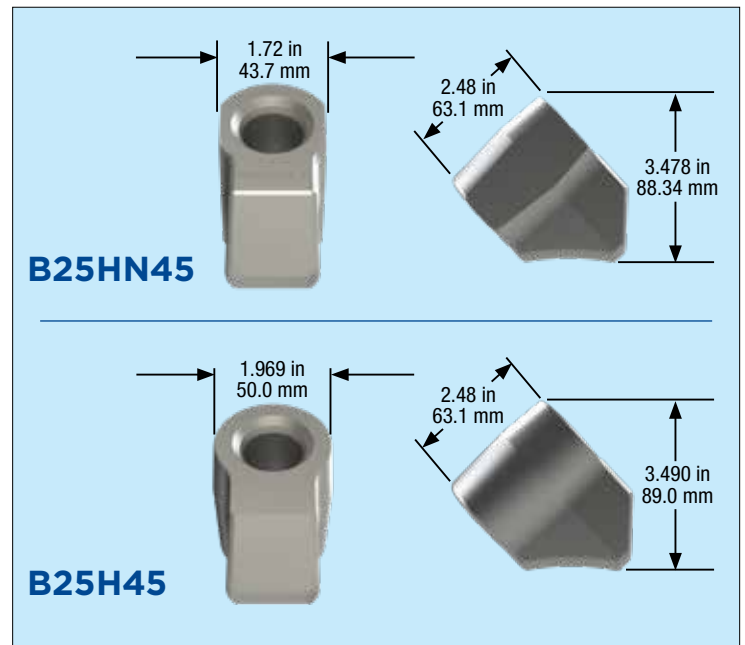

Proudly made in the U.S.A.

# Trenching



Detailed view of carbide tip

## Features:

- Standard body design 2.5 in/64.0 mm gauge
- Wide-flare shoulder provides maximum block and face protection
- Design evenly distributes impact loads through tool shoulder

Tool Part Number	Shank (in, mm)	Width (in, mm)	Tip Diameter (in, mm)	Gauge (in, mm)	Pieces per Box	Pieces per Pallet
TR74	1.0 in 25.0 mm	2.5 in 64.0 mm	0.708 in 17.98 mm	2.5 in 64.0 mm	15	900
TR75	1.0 in 25.0 mm	2.5 in 64.0 mm	0.817 in 20.75 mm	2.5 in 64.0 mm	15	900
TR76	1.0 in 25.0 mm	2.5 in 64.0 mm	0.93 in 23.62 mm	2.5 in 64.0 mm	15	900

Block Part Number	Bore Hole Diameter (in, mm)	Width (in, mm)	Angle (degrees)	Internal Groove	Pieces per Box	Pieces per Pallet
B25HN45	1.012 in 25.71 mm	1.72 in 43.7 mm	45°	Yes	15	900
B25H45	1.012 in 25.71 mm	1.969 in 50.0 mm	45°	Yes	8	480
B25H50S	1.012 in 25.71 mm	2.63 in 66.8 mm	50°	Yes	6	360
B25H50L	1.012 in 25.71 mm	2.63 in 66.8 mm	50°	Yes	6	360

## TR74

Carbide Hybrid (Plug/Valve Seat)

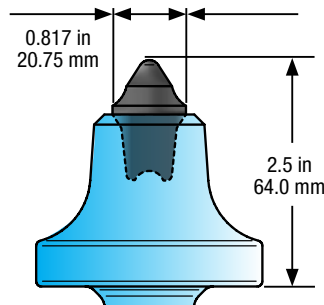
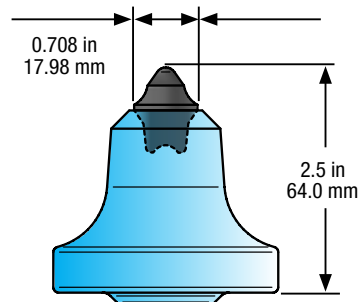

## TR75

Carbide Hybrid (Plug/Valve Seat)

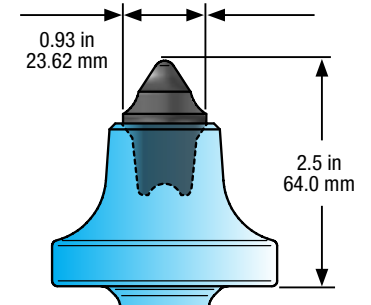

## TR76

Carbide Hybrid (Plug/Valve Seat)

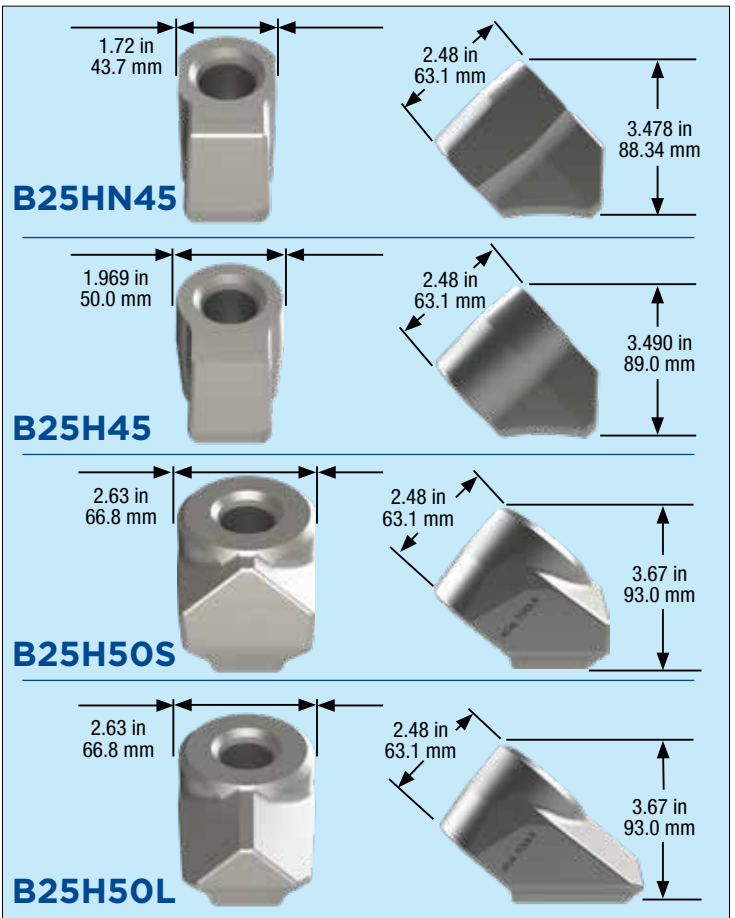

Proudly made in the U.S.A.

# Trenching



## Features:

- Standard body design 3 in/75 mm gauge
- Wide-flare shoulder provides maximum block and face protection
- Design evenly distributes impact loads through tool shoulder

Tool Part Number	Shank (in, mm)	Shoulder (in, mm)	Tip Diameter (in, mm)	Gauge (in, mm)	Pieces per Box	Pieces per Pallet
TRG74	1.0 in 25.0 mm	2.5 in 64.0 mm	0.708 in 18.0 mm	3.0 in 75.0 mm	15	900
TRG75	1.0 in 25.0 mm	2.5 in 64.0 mm	0.817 in 20.75 mm	3.0 in 75.0 mm	15	900

Block Part Number	Bore Hole Diameter (in, mm)	Width (in, mm)	Angle (degrees)	Internal Groove	Pieces per Box	Pieces per Pallet
B25HN45	1.012 in 25.71 mm	1.72 in 43.7 mm	45°	Yes	15	900
B25H45	1.012 in 25.71 mm	1.969 in 50.0 mm	45°	Yes	8	480
B25H50S	1.012 in 25.71 mm	2.63 in 66.8 mm	50°	Yes	6	360
B25H50L	1.012 in 25.71 mm	2.63 in 66.8 mm	50°	Yes	6	360

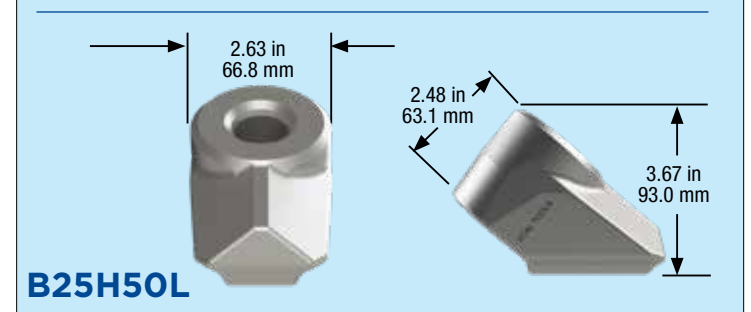
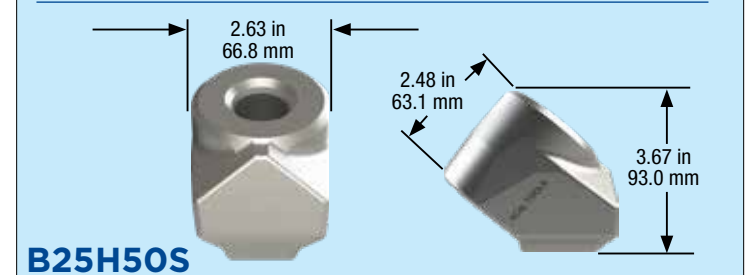
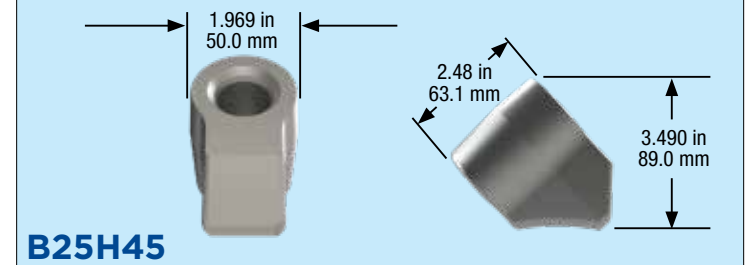
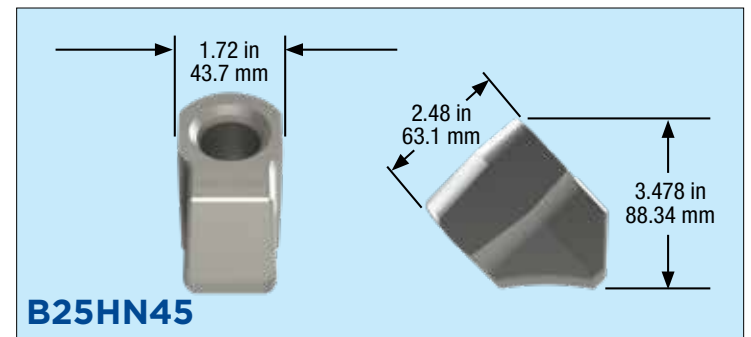
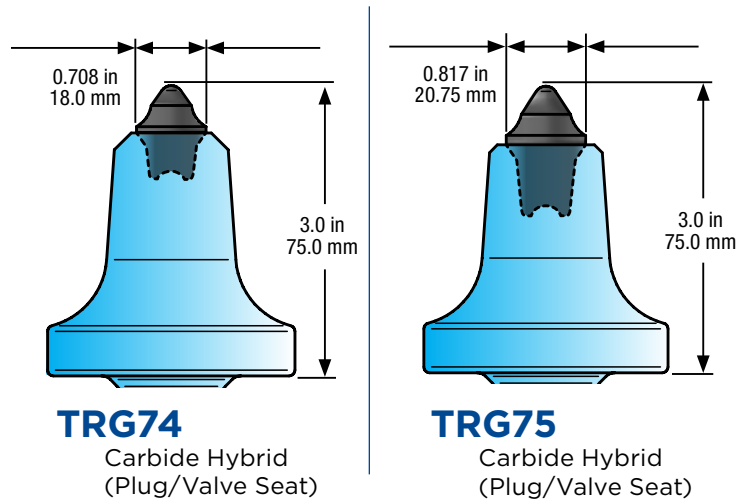

Proudly made in the U.S.A.



# Trenching (C- Groove Series)



## Features:

- Standard body design 2.5 in/64.0 mm gauge
- Wide-flare shoulder provides maximum block and face protection
- Step-shank design for improved strength

Tool Part Number	Shank (in, mm)	Shoulder (in, mm)	Tip Diameter (in, mm)	Gauge (in, mm)	Pieces per Box	Pieces per Pallet
TX23	1.5 in 30.0 mm	2.5 in 64.0 mm	0.945 in 24.0 mm	2.5 in 64.0 mm	10	600
TX39	1.5 in 30.0 mm	2.5 in 64.0 mm	0.775 in 19.68 mm	2.5 in 64.0 mm	10	600
TX74	1.5 in 30.0 mm	2.5 in 64.0 mm	0.708 in 17.98 mm	2.5 in 64.0 mm	10	600
TX75	1.5 in 30.0 mm	2.5 in 64.0 mm	0.817 in 20.75 mm	2.5 in 64.0 mm	10	600
TX76	1.5 in 30.0 mm	2.5 in 64.0 mm	0.93 in 23.62 mm	2.5 in 64.0 mm	10	600

Block Part Number	Bore Hole Diameter (in, mm)	Width (in, mm)	Angle (degrees)	Internal Groove	Pieces per Box	Pieces per Pallet
B38HD50S	1.50 in 38.23 mm	3.25 in 82.5 mm	50°	Yes	8	480
B38HD50L	1.50 in 38.23 mm	3.25 in 82.5 mm	50°	Yes	8	480

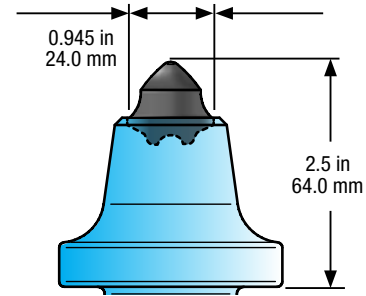

**TX23**  
Carbide Valve Seat

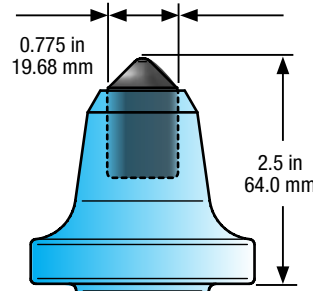

**TX39**  
Carbide Plug

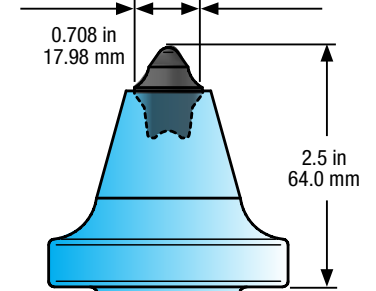

**TX74**  
Carbide Hybrid  
(Plug/Valve Seat)

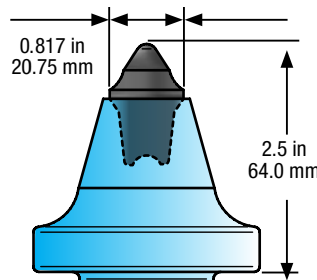

**TX75**  
Carbide Hybrid  
(Plug/Valve Seat)

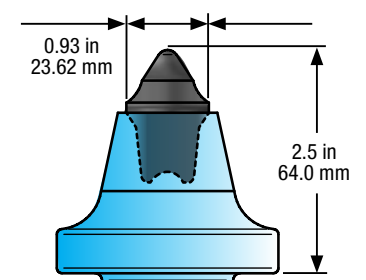

**TX76**  
Carbide Hybrid  
(Plug/Valve Seat)

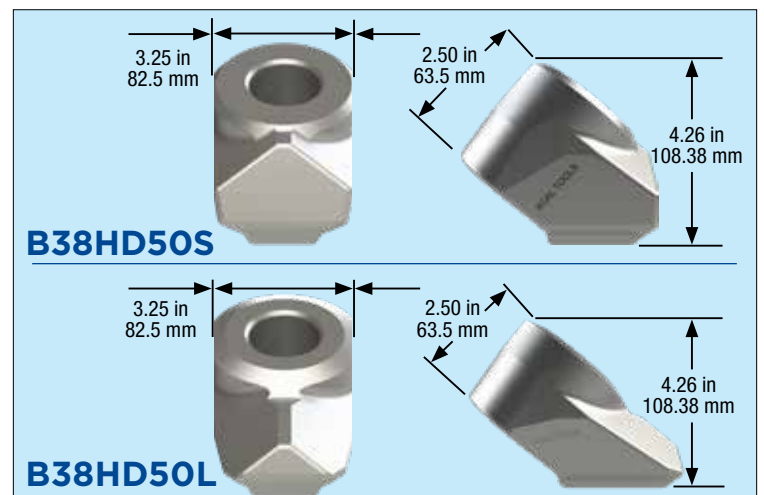

Proudly made in the U.S.A.

# Trenching (C- Groove Series)



## Features:

- Standard body design 3 in/75 mm gauge
- Wide-flare shoulder provides maximum block and face protection
- Step-shank design for improved strength

Tool Part Number	Shank (in, mm)	Shoulder (in, mm)	Tip Diameter (in, mm)	Gauge (in, mm)	Pieces per Box	Pieces per Pallet
TXF20	1.5 in 30.0 mm	2.5 in 64.0 mm	1.30 in 33.0 mm	3.0 in 75.0 mm	10	600
TXF39	1.5 in 30.0 mm	2.5 in 64.0 mm	0.775 in 19.68 mm	3.0 in 75.0 mm	10	600
TXF56	1.5 in 30.0 mm	2.5 in 64.0 mm	0.79 in 20.2 mm	3.0 in 75.0 mm	10	600
TXF74	1.5 in 30.0 mm	2.5 in 64.0 mm	0.708 in 17.98 mm	3.0 in 75.0 mm	10	600
TXF74P	1.5 in 30.0 mm	2.5 in 64.0 mm	0.708 in 17.98 mm	3.0 in 75.0 mm	10	600

Block Part Number	Bore Hole Diameter (in, mm)	Width (in, mm)	Angle (degrees)	Internal Groove	Pieces per Box	Pieces per Pallet
B38HD50S	1.50 in 38.23 mm	3.25 in 82.5 mm	50°	Yes	8	480
B38HD50L	1.50 in 38.23 mm	3.25 in 82.5 mm	50°	Yes	8	480

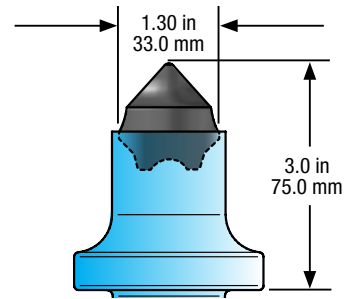

**TXF20**  
Carbide Valve Seat

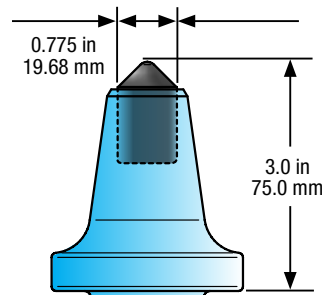

**TXF39**  
Carbide Plug

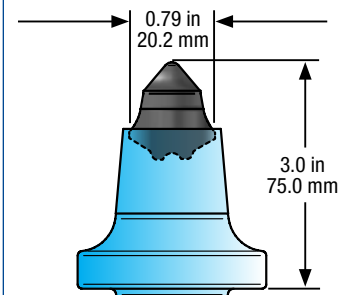

**TXF56**  
Carbide Valve Seat

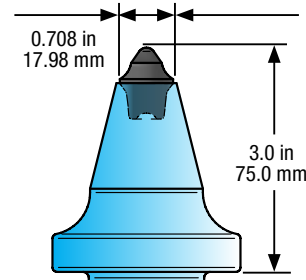

**TXF74**  
Carbide Hybrid  
(Plug/Valve Seat)

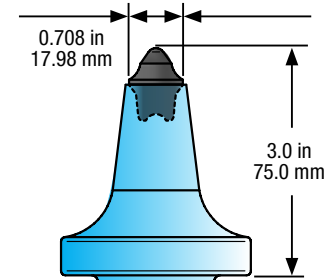

**TXF74P**  
Carbide Hybrid  
(Plug/Valve Seat)

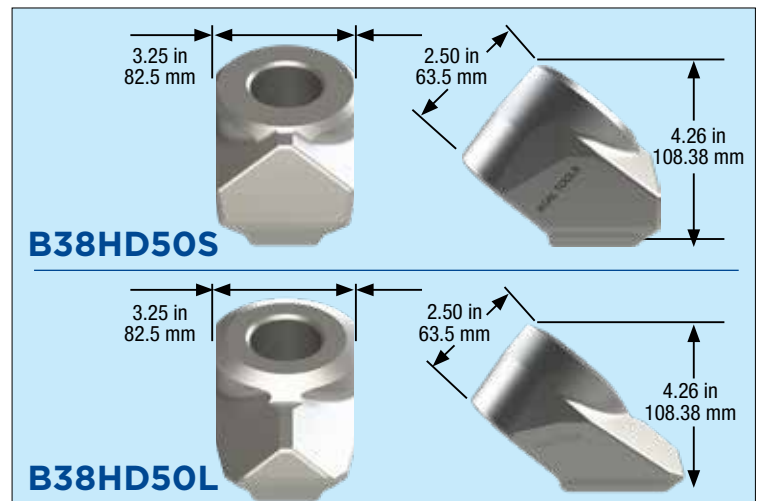

Proudly made in the U.S.A.

# Trenching (C- Groove Series)



## Features:

- Standard body design 3 in/75 mm gauge
- Narrow body for efficient penetration
- Wide-flare shoulder provides maximum block and face protection
- Step-shank design for improved strength

Tool Part Number	Shank (in, mm)	Shoulder (in, mm)	Tip Diameter (in, mm)	Gauge (in, mm)	Pieces per Box	Pieces per Pallet
TXF75	1.5 in 30.0 mm	2.5 in 64.0 mm	0.817 in 20.75 mm	3.0 in 75.0 mm	10	600
TXF76	1.5 in 30.0 mm	2.5 in 64.0 mm	0.93 in 23.62 mm	3.0 in 75.0 mm	10	600
TXF78	1.5 in 30.0 mm	2.5 in 64.0 mm	0.976 in 24.79 mm	3.0 in 75.0 mm	10	600

Block Part Number	Bore Hole Diameter (in, mm)	Width (in, mm)	Angle (degrees)	Internal Groove	Pieces per Box	Pieces per Pallet
B38H50S	1.50 in 38.23 mm	2.630 in 66.8 mm	50°	Yes	12	480
B38H50L	1.50 in 38.23 mm	2.630 in 66.8 mm	50°	Yes	8	480
B38HD50S	1.50 in 38.23 mm	3.25 in 82.5 mm	50°	Yes	8	480
B38HD50L	1.50 in 38.23 mm	3.25 in 82.5 mm	50°	Yes	8	480

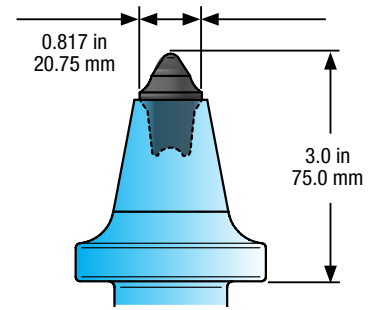

**TXF75**  
Carbide Hybrid (Plug/Valve Seat)

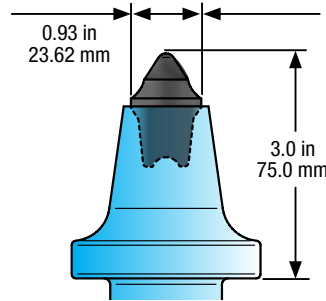

**TXF76**  
Carbide Hybrid (Plug/Valve Seat)

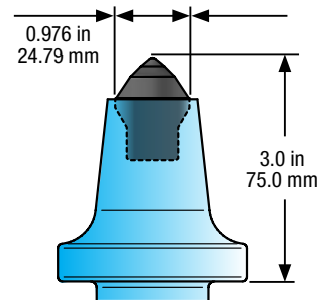

**TXF78**  
Wide-Top Carbide Hybrid

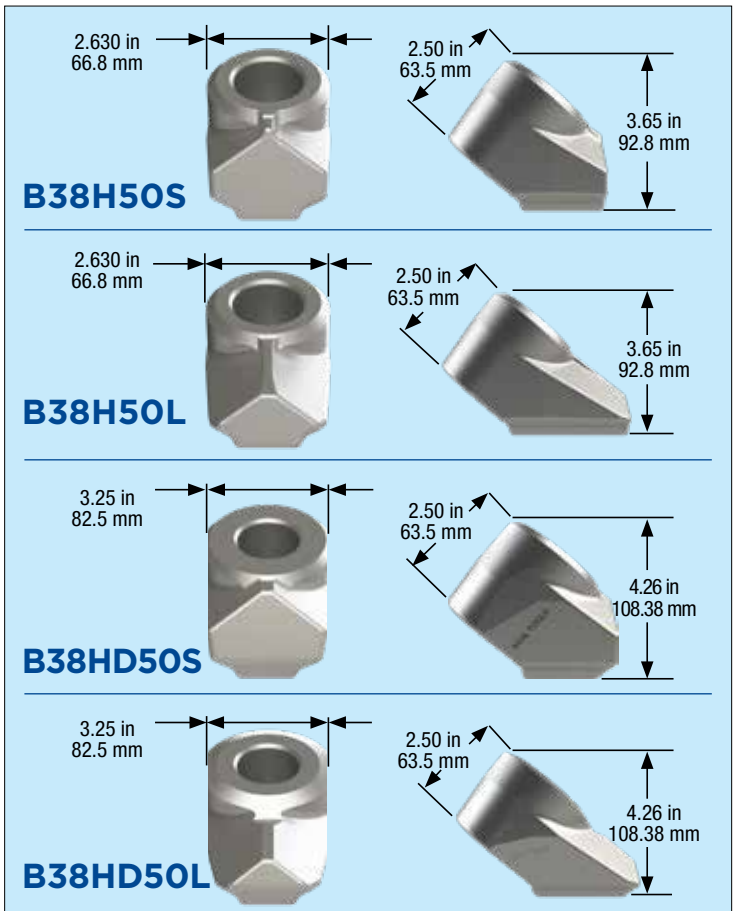

Proudly made in the U.S.A.



# Trenching (C- Groove Series)



Detailed view of carbide tip

## Features:

- Standard body design 3.5 in/89 mm gauge
- Narrow body for efficient penetration
- Wide-flare shoulder provides maximum block and face protection
- Step-shank design for improved strength

Tool Part Number	Shank (in, mm)	Shoulder (in, mm)	Tip Diameter (in, mm)	Gauge (in, mm)	Pieces per Box	Pieces per Pallet
TXV74	1.5 in 30.0 mm	2.5 in 64.0 mm	0.708 in 17.98 mm	3.5 in 89.0 mm	10	600
TXV74P	1.5 in 30.0 mm	2.5 in 64.0 mm	0.708 in 17.98 mm	3.5 in 89.0 mm	10	600
TXV75	1.5 in 30.0 mm	2.5 in 64.0 mm	0.817 in 20.75 mm	3.5 in 89.0 mm	10	600
TXV76	1.5 in 30.0 mm	2.5 in 64.0 mm	0.93 in 23.62 mm	3.5 in 89.0 mm	10	600
TXV78	1.5 in 30.0 mm	2.5 in 64.0 mm	0.97 in 24.7 mm	3.5 in 89.0 mm	10	600

Block Part Number	Bore Hole Diameter (in, mm)	Width (in, mm)	Angle (degrees)	Internal Groove	Pieces per Box	Pieces per Pallet
B38HD50S	1.50 in 38.23 mm	3.25 in 82.5 mm	50°	Yes	8	480
B38HD50L	1.50 in 38.23 mm	3.25 in 82.5 mm	50°	Yes	8	480

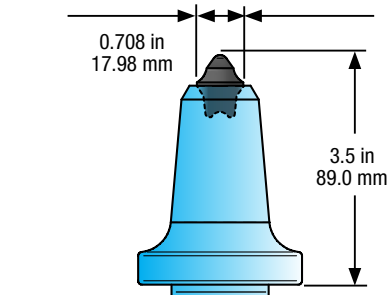

**TXV74**  
Carbide Hybrid (Plug/Valve Seat)

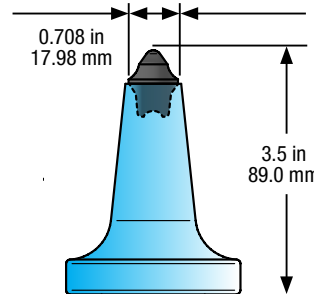

**TXV74P**  
Carbide Hybrid (Plug/Valve Seat)

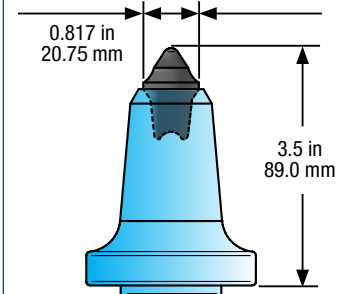

**TXV75**  
Carbide Hybrid (Plug/Valve Seat)

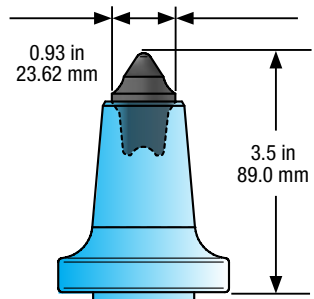

**TXV76**  
Carbide Hybrid (Plug/Valve Seat)

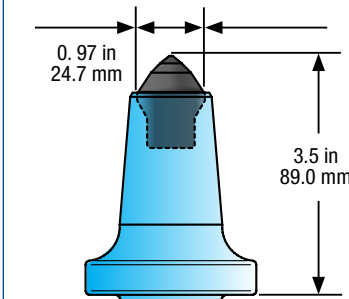

**TXV78**  
Wide-Top Carbide Hybrid

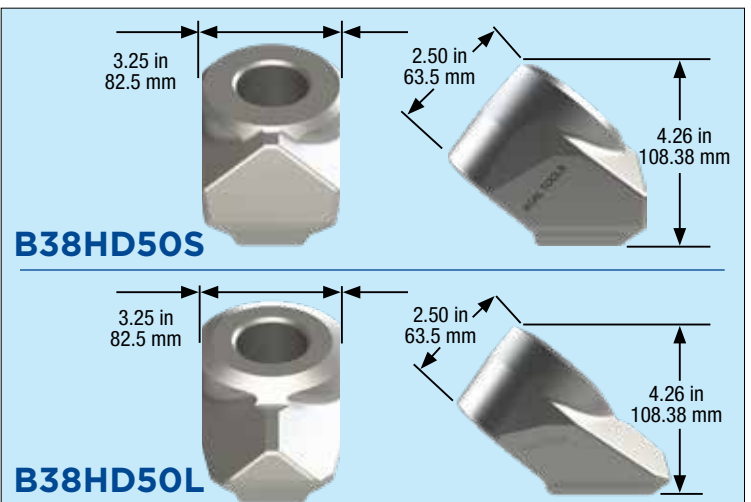

**B38HD50S**

**B38HD50L**



Proudly made in the U.S.A.

# Trenching (Snap Ring Series)

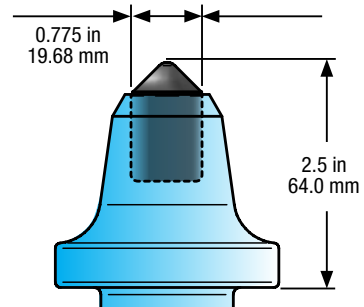

**TX39K**  
Carbide Plug

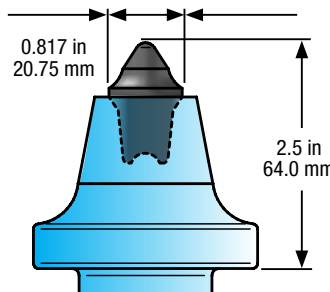

**TX75K**  
Carbide Hybrid  
(Plug/Valve Seat)

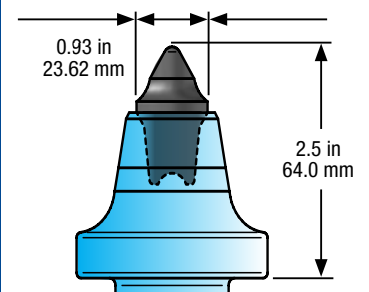

**TX76K**  
Carbide Hybrid  
(Plug/Valve Seat)

## Features:

- Narrow body for efficient penetration
- Wide-flare shoulder provides maximum block and face protection
- Step-shank design for improved strength

Tool Part Number	Shank (in, mm)	Shoulder (in, mm)	Tip Diameter (in, mm)	Gauge (in, mm)	Pieces per Box	Pieces per Pallet
TX39K	1.5 in 30.0 mm	2.5 in 64.0 mm	0.775 in 19.68 mm	2.5 in 64.0 mm	10	600
TX75K	1.5 in 30.0 mm	2.5 in 64.0 mm	0.817 in 20.75 mm	2.5 in 64.0 mm	10	600
TX76K	1.5 in 30.0 mm	2.5 in 64.0 mm	0.93 in 23.62 mm	2.5 in 64.0 mm	10	600

Block Part Number	Bore Hole Diameter (in, mm)	Width (in, mm)	Angle (degrees)	Internal Groove	Pieces per Box	Pieces per Pallet
B38H50S	1.50 in 38.23 mm	2.630 in 66.8 mm	50°	Yes	8	480
B38H50L	1.50 in 38.23 mm	2.630 in 66.8 mm	50°	Yes	8	480
B38HD50S	1.50 in 38.23 mm	3.25 in 82.5 mm	50°	Yes	8	480
B38HD50L	1.50 in 38.23 mm	3.25 in 82.5 mm	50°	Yes	8	480

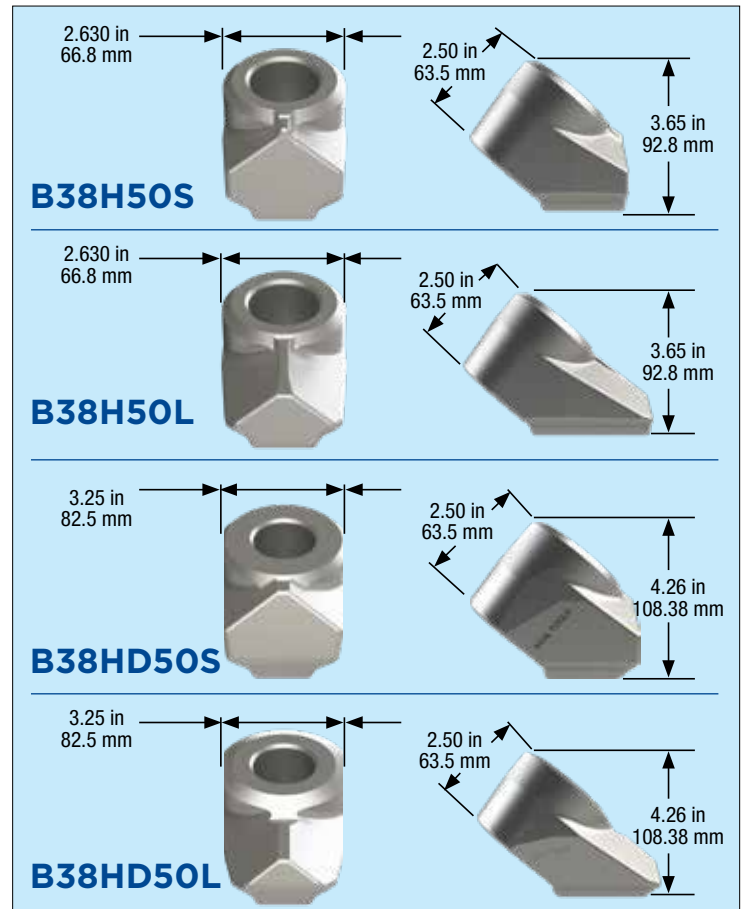

Proudly made in the U.S.A.

# Trenching (Snap Ring Series)



Detailed view of carbide tip

## Features:

- Narrow body for efficient penetration
- Wide-flare shoulder provides maximum block and face protection
- Step-shank design for improved strength

Tool Part Number	Shank (in, mm)	Shoulder (in, mm)	Tip Diameter (in, mm)	Gauge (in, mm)	Pieces per Box	Pieces per Pallet
TXF20K	1.5 in 30.0 mm	2.5 in 64.0 mm	1.30 in 33.02 mm	3.0 in 75.0 mm	10	600
TXF39K	1.5 in 30.0 mm	2.5 in 64.0 mm	0.775 in 19.68 mm	3.0 in 76.0 mm	10	600
TXF74K	1.5 in 30.0 mm	2.5 in 64.0 mm	0.708 in 17.98 mm	3.0 in 75.0 mm	10	600
TXF74KP	1.5 in 30.0 mm	2.5 in 64.0 mm	0.708 in 17.98 mm	3.0 in 75.0 mm	10	600

Block Part Number	Bore Hole Diameter (in, mm)	Width (in, mm)	Angle (degrees)	Internal Groove	Pieces per Box	Pieces per Pallet
B38H50S	1.50 in 38.23 mm	2.630 in 66.8 mm	50°	Yes	8	480
B38H50L	1.50 in 38.23 mm	2.630 in 66.8 mm	50°	Yes	8	480
B38HD50S	1.50 in 38.23 mm	3.25 in 82.5 mm	50°	Yes	8	480
B38HD50L	1.50 in 38.23 mm	3.25 in 82.5 mm	50°	Yes	8	480

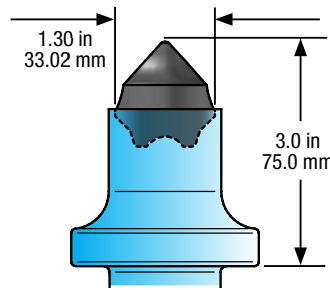

**TXF20K**  
Carbide Valve Seat

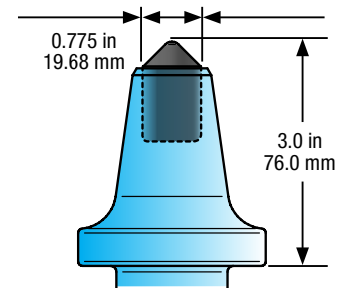

**TXF39K**  
Carbide Plug

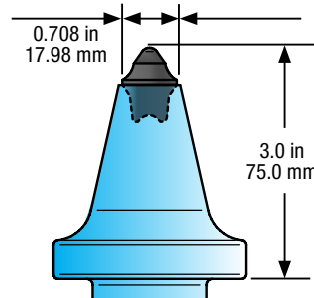

**TXF74K**  
Carbide Hybrid  
(Plug/Valve Seat)

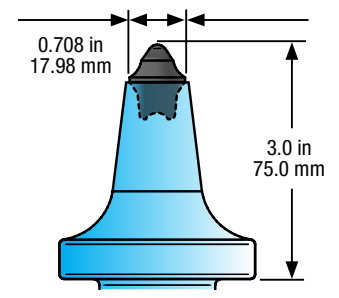

**TXF74KP**  
Carbide Hybrid  
(Plug/Valve Seat)

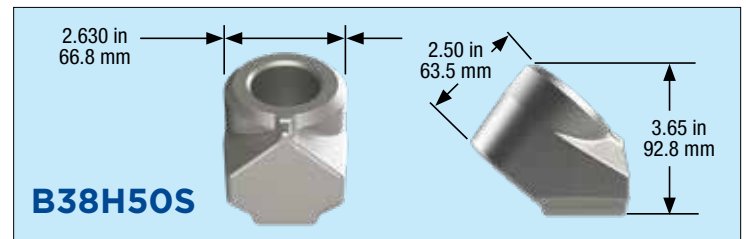

**B38H50S**

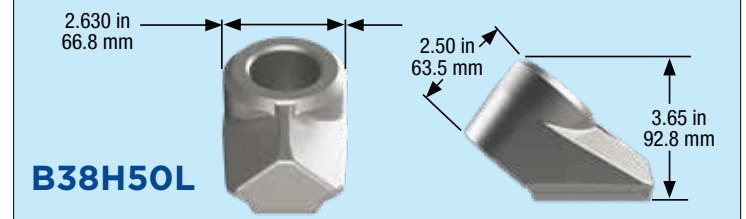

**B38H50L**

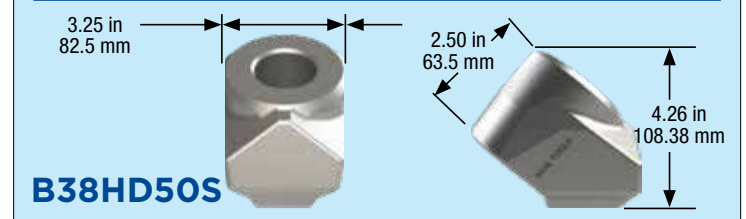

**B38HD50S**

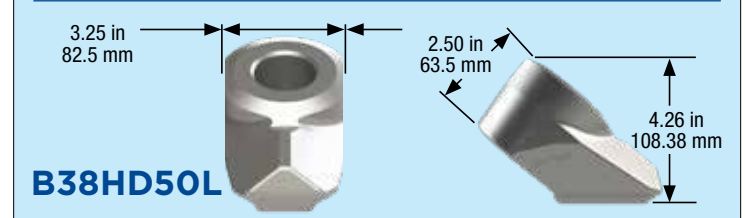

**B38HD50L**



Proudly made in the U.S.A.

# Trenching (Snap Ring Series)

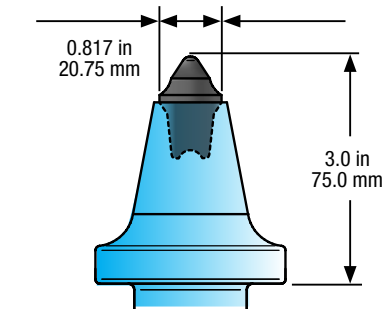

**TXF75K**  
Carbide Hybrid (Plug/Valve Seat)

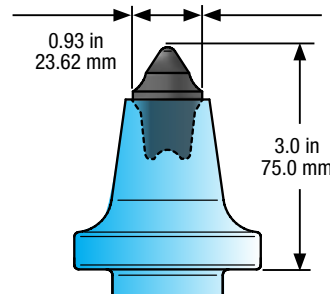

**TXF76K**  
Carbide Hybrid (Plug/Valve Seat)

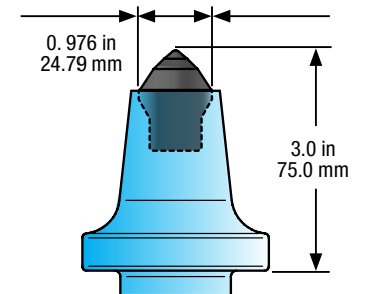

**TXF78K**  
Wide-Top Carbide Hybrid

## Features:

- Narrow body for efficient penetration
- Wide-flare shoulder provides maximum block and face protection
- Step-shank design for improved strength

Tool Part Number	Shank (in, mm)	Shoulder (in, mm)	Tip Diameter (in, mm)	Gauge (in, mm)	Pieces per Box	Pieces per Pallet
TXF75K	1.5 in 30.0 mm	2.5 in 64.0 mm	0.817 in 20.75 mm	3.0 in 75.0 mm	10	600
TXF76K	1.5 in 30.0 mm	2.5 in 64.0 mm	0.93 in 23.62 mm	3.0 in 75.0 mm	10	600
TXF78K	1.5 in 30.0 mm	2.5 in 64.0 mm	0.976 in 24.79 mm	3.0 in 75.0 mm	10	600

Block Part Number	Bore Hole Diameter (in, mm)	Width (in, mm)	Angle (degrees)	Internal Groove	Pieces per Box	Pieces per Pallet
B38H50S	1.50 in 38.23 mm	2.630 in 66.8 mm	50°	Yes	8	480
B38H50L	1.50 in 38.23 mm	2.630 in 66.8 mm	50°	Yes	8	480
B38HD50S	1.50 in 38.23 mm	3.25 in 82.5 mm	50°	Yes	8	480
B38HD50L	1.50 in 38.23 mm	3.25 in 82.5 mm	50°	Yes	8	480

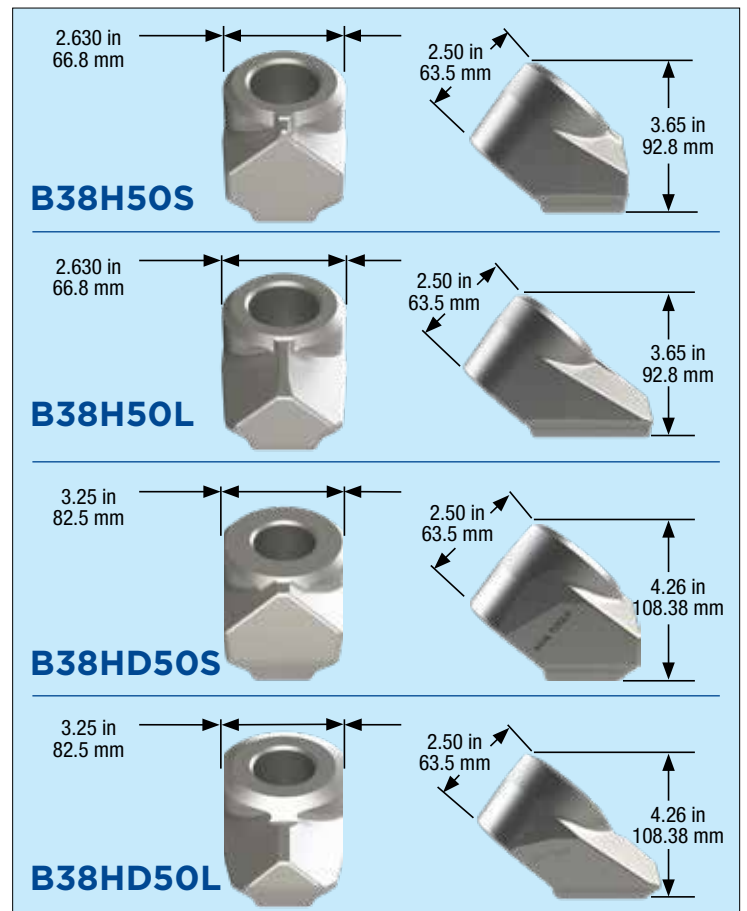

Proudly made in the U.S.A.

# Trenching (Snap Ring Series)



## Features:

- Narrow body for efficient penetration
- Wide-flare shoulder provides maximum block and face protection
- Step-shank design for improved strength

Tool Part Number	Shank (in, mm)	Shoulder (in, mm)	Tip Diameter (in, mm)	Gauge (in, mm)	Pieces per Box	Pieces per Pallet
TXV74KP	1.5 in 30.0 mm	2.5 in 64.0 mm	0.708 in 17.98 mm	3.5 in 89.0 mm	10	600
TXV75K	1.5 in 30.0 mm	2.5 in 64.0 mm	0.817 in 20.75 mm	3.5 in 89.0 mm	10	600
TXV76K	1.5 in 30.0 mm	2.5 in 64.0 mm	0.93 in 23.62 mm	3.5 in 89.0 mm	10	600
TXV78K	1.5 in 30.0 mm	2.5 in 64.0 mm	0.97 in 24.79 mm	3.5 in 89.0 mm	10	600

Block Part Number	Bore Hole Diameter (in, mm)	Width (in, mm)	Angle (degrees)	Internal Groove	Pieces per Box	Pieces per Pallet
B38HD50S	1.50 in 38.23 mm	3.25 in 82.5 mm	50°	Yes	8	480
B38HD50L	1.50 in 38.23 mm	3.25 in 82.5 mm	50°	Yes	8	480

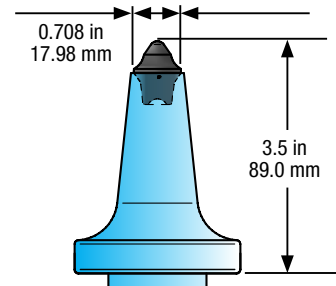

**TXV74KP**  
Carbide Hybrid (Plug/Valve Seat)

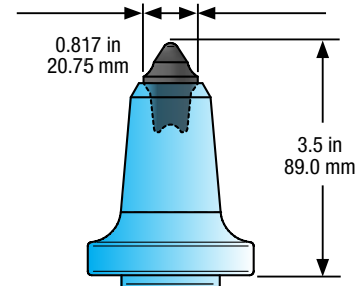

**TXV75K**  
Carbide Hybrid (Plug/Valve Seat)

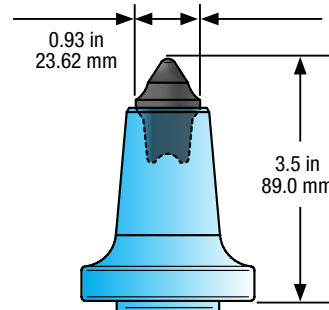

**TXV76K**  
Carbide Hybrid (Plug/Valve Seat)

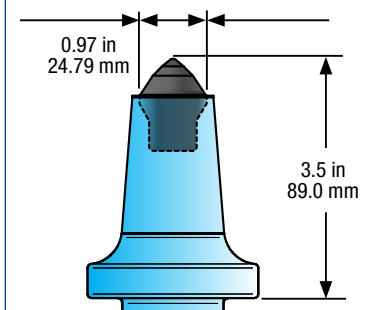

**TXV78K**  
Wide-Top Carbide Hybrid

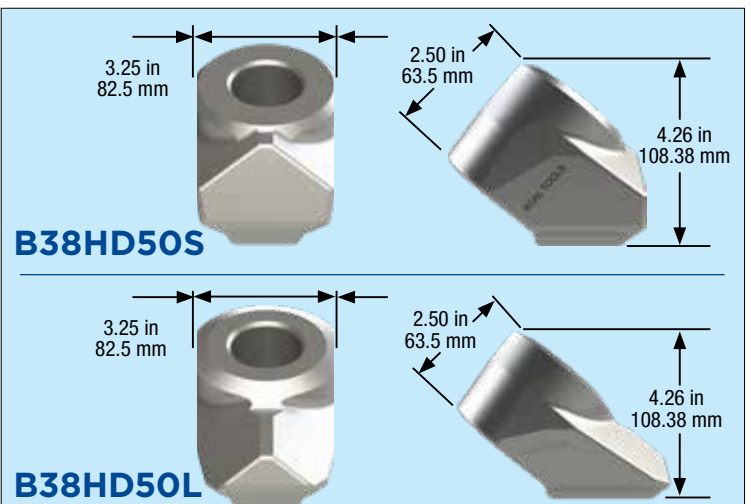

Proudly made in the U.S.A.



## Accessories



### Curved Knock Out Punch with Handle

- Tool remover with carbide tip for extended life

Part Number Product Code	CKP
-----------------------------	-----



### Installation Remover

- For removal of c-clip

Part Number Product Code(s)	CC25, CC30
--------------------------------	------------



### Forked Puller

- For removal of tools

Part Number Product Code(s)	FP19, FP22, FP25
--------------------------------	------------------



### Wedge Puller

- For removal of shank tools with collars

Part Number Product Code	W25
-----------------------------	-----



### Snap Ring Pliers

- For removal of snap rings

Part Number Product Code	SRP86/Ratchet Snap Ring Pliers
-----------------------------	--------------------------------





AS PART OF THE XCAL TOOLS COMPANY,  
TAMCO PROUDLY OFFERS A FULL LINE OF AIR  
AND PNEUMATIC CONSTRUCTION TOOLS.

SCAN  
QR CODE  
FOR THE FULL  
CATALOG



## Boom Mounted Demo Steel

# TAMCO'S MOST POPULAR BRANDS

We currently stock the brands you rely on and offer a line of boom mounted demo tools for these manufacturers.

	BOOM MOUNTED DEMO TOOLS	STOCKED BRANDS
<i>Allied</i>	X	X
<i>Atlas Copco/Epiroc</i>	X	X
<i>Bobcat/Melroe</i>	X	X
<i>CP</i>	-	X
<i>Husky/IPC</i>	X	X
<i>Indeco</i>	X	X
<i>Kent/FRD</i>	X	X
<i>Magnum</i>	X	X
<i>NPK</i>	X	X
<i>Okada</i>	X	X
<i>Rammer</i>	X	-
<i>Stanley</i>	X	-
<i>Teledyne</i>	X	-
<i>Toku/Striker</i>	X	X
<i>Toro-Dingo</i>	-	X
<i>Tramac</i>	X	X

ATLAS COPCO/EPIROC	KENT/FRD	NPK	CHICAGO PNEUMATIC	STRIKER/TOKU	OKADA	BOBCAT
SB52	KF1/FX15	GH2	RX 3	TNB-2M	TOP35	HB680
SB102	KF2/FX25	GH3	RX 4	TNB-3M	TOP45	HB880
SBU160	KF3/KF3/FX35	GH4	RX 6	TNB-4M	TOP60	HB980
SB202/SBU220	KF4/FX45	GH6	RX 8	TNB-5M	TOP100	HB1180
PB210	KF5/FX55	GH9	RX 11	TNB-6E	TOP200	
SB302/SBU340	KF6/FX65	GH10	RX 25/26			
SB452	KF12	GH12	RX 29			
SB552	KF19	GH15	RX 45/46			
MB500	KF27	GH18				
MB700	FX125					
MB750	FX175					
MB1000	FX275					
MB1200	FX375					
MB1500	FX475					
HB3000	-					
HB3600	-					

**CALL FOR PRICING**  
- MADE TO ORDER -



1		Moil Point	4		Wide Cross-Cut Chisel
2		Cross-Cut Chisel	5		Wide Inline Chisel
3		Inline Chisel	6		Blunt



15020 INDUSTRIAL PARK ROAD  
BRISTOL, VA USA  
(276) 644-3520

[www.xcaltools.com](http://www.xcaltools.com)

