



XCAL
TOOLS



DRILLING

All Locations

XCAL TOOLS of Clare

314 E. 4th Street
Clare, MI 48617
Ph: (989) 386-5376

XCAL TOOLS of Madisonville

3957 Anton Road
Madisonville, KY 42431
Ph: (270) 825-BITS (2487)

XCAL TOOLS of South Point

235 Commerce Drive
South Point, OH 45680
Ph: (740) 377-3354
Fax: (740) 377-3363

XCAL Industries

843 Lochgelly Road
Oak Hill, WV 25901
Ph: (304) 469-4721
Fax: (304) 469-4750

XCAL TOOLS of Beckley

256 Industrial Drive
Oak Hill, WV 25901
Ph: (304) 465-0651
Fax: (304) 465-5244

XCAL TOOLS of Bristol

15020 Industrial Park Road
Bristol, VA 24202
Ph: (276) 644-3520
Fax: (276) 644-3523





SUPERIOR QUALITY

XCAL TOOLS takes pride in manufacturing and selling a full line of road planing, soil stabilization, reclaiming, grading, trenching and foundation drilling bits and carbide tooling products that are American-made. Our inhouse operations gives us the flexibility to quickly test and adapt to changing environments and customer needs. Our cost effective production methods, allows us to provide a exceptional product of the highest quality.



SERVICE AND INNOVATION

For over 20 years, our carbide producer XCAL INDUSTRIES, has been producing high quality carbide for the mining, roof drilling, snow and ice removal, road planing, wear products and metal cutting blanks, producing over fifty grades of cemented carbide and the capability to develop extra coarse, tougher grades to meet the demands of the industry.

These affiliates of JENNMAR, in collaboration with each other, can provide you with superior quality products and unmatched customer service. Our commitment to the customer is guided by three words; SAFETY, SERVICE, and INNOVATION. It's these words that form the foundation of our business. It's who we are.





Table of Contents

DRILLING

Carbide Tips.....	8
The Hybrid Difference.....	9
Accessories.....	20

18MM

TB01.....	10
TB03.....	10
TB73.....	10
B18L45.....	10
B18H45.....	10
B18HT45.....	10

19MM

TC403L.....	11
TC403.....	11
TC473.....	11
B19L45.....	11
B19H45.....	11
B19HT45.....	11

22MM

TJ401.....	12
TJ403.....	12
TJ474.....	12
TJ401L.....	13
TJ403L.....	13
TJ474L.....	13
TJ486L.....	13
B22NR45.....	12-13
B22H45.....	12-13
B22HT45.....	12-13

25MM

DR35.....	14
DR73.....	14
DR74.....	14
DR75.....	14
DR76.....	14
DRW73.....	15
DRW74.....	15
DRW75.....	15
DRW76.....	15
B25HN45.....	14-15
B25H45.....	14-15

38X30MM

DX19.....	16
DX21.....	16
DX76.....	16
DXW20.....	17
DXW21.....	17
DXW76.....	17
DXL08K.....	18
DXL74K.....	18
DXL75K.....	18
B38H45.....	16-18
B38R.....	16-18
XJL7.....	19

TAMCO TOOLS

Air Tool Accessories.....	21
Manifolds, Whip Checks, and Air Tool Oil.....	22
Thread Rock Bits.....	23

Carbide Tips

We are an ISO 9001 certified facility that offers a wide range of carbide tips to match the various challenges that you might face. Producing over fifty grades of cemented carbide and the ability to create new ones, we can find a carbide grade to meet your needs. Our versatility helps us to check and respond easily to evolving conditions and customer needs. All of our tips provide superb penetration and maximum productivity - regardless of whether you work in soft, medium-hard or extremely hard and demanding conditions.



Retainers Selection

Our retainer selection keeps tool changes quick and reduces your downtime



Proudly made in the U.S.A.

The Hybrid Difference

XCAL TOOLS hybrid design gives you a blend of the efficient cutting characteristics of our CAP designs, combined with the durability and long life of a plug tip. Our design provides excellent penetration while retaining maximum strength, shear resistance and durability in challenging conditions, improves safety, efficiency and working conditions— leading to increased performance, productivity and lowered production costs.



Cap Carbide Tips

For superior penetration: the larger carbide shoulder provides excellent protection against steel wash.

Insert Carbide Tips

For high-impact conditions, or working with hard materials where steel wash is not an issue.

The Hybrid Carbide Tip

The tapered bottom design provides more strength where it's needed most, helping to prevent carbide fracture.



Cap Carbide Tips

Valve seat carbide tips are preferred over flat bottom tips providing a stronger bond between the carbide and steel giving more stability and support in highly abrasive conditions.



Insert Carbide Tips

Insert carbide tips are best for penetration applications where steel wash is not an issue. These tips provide a strong bond between carbide and steel giving more stability and support proving ideal for use in hard, high-impact conditions.



Hybrid Carbide Tips

Hybrid tips were developed for all cutting requirements - no matter how tough. You won't need to switch tools when your conditions change.



Wide-Top Carbide Tips

Wide-Top tip combines the abrasive resistance of a cap tip with the impact resistance of a plug tip to maximise strength and steel support for ultimate durability in the most challenging conditions.



Proudly made in the U.S.A.

Drilling

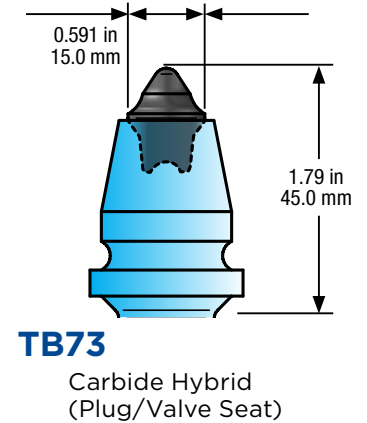
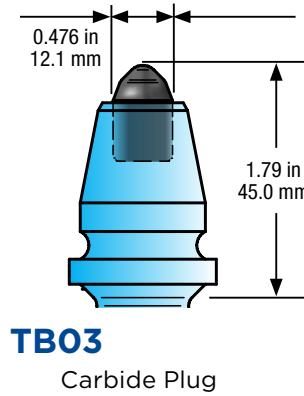
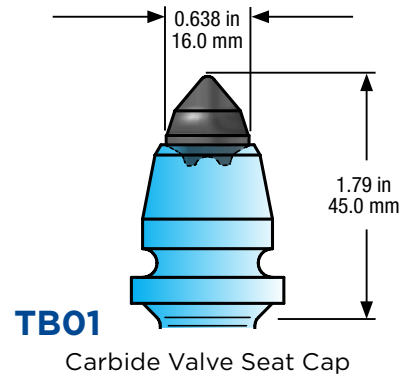

Features:

- Standard body design
- Used for Core Barrels and Augers
- Puller groove for easy tool removal
- Interchangeable series offers flexibility

Tool Part Number	Shank (in, mm)	Shoulder (in, mm)	Tip Diameter (in, mm)	Gauge (in, mm)	Pieces per Box	Pieces per Pallet
TB01	0.72 in 18.0 mm	1.0 in 25.4 mm	0.638 in 16.0 mm	1.79 in 45.0 mm	65	3900
TB03	0.72 in 18.0 mm	1.0 in 25.4 mm	0.476 in 12.1 mm	1.79 in 45.0 mm	65	3900
TB73	0.72 in 18.0 mm	1.0 in 25.4 mm	0.591 in 15.0 mm	1.79 in 45.0 mm	65	3900

Block Part Number	Bore Hole Diameter (in, mm)	Width (in, mm)	Angle (degrees)	Internal Groove	Pieces per Box	Pieces per Pallet
B18L45	.750 in 19.05 mm	1.375 in 34.9 mm	45°	Yes	35	2100
B18H45	.750 in 19.05 mm	1.625 in 41.28 mm	45°	Yes	35	2100
B18HT45	.750 in 19.05 mm	1.654 in 42.0 mm	45°	Yes	20	900

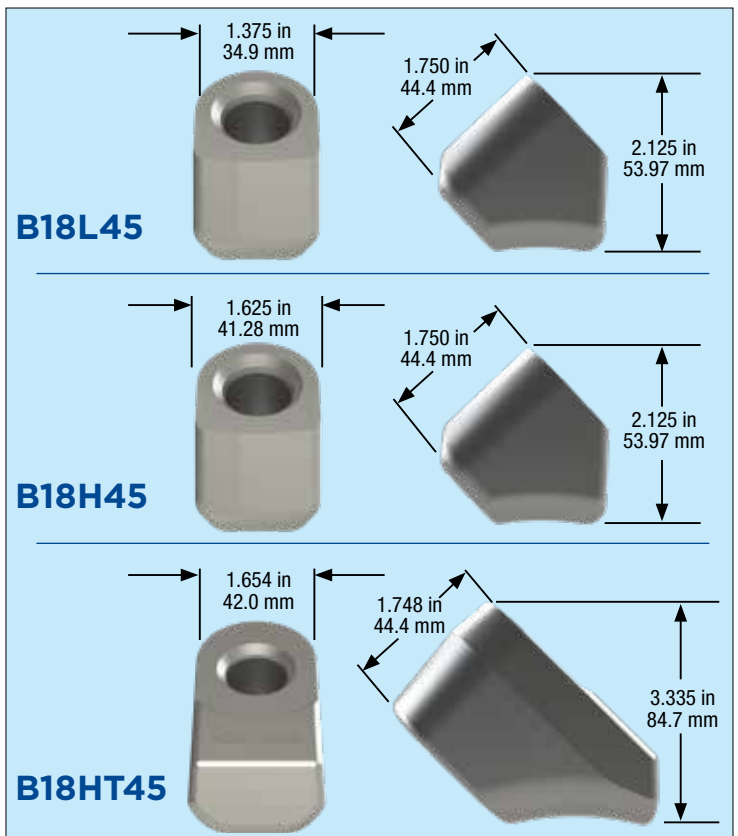

Proudly made in the U.S.A.

Drilling

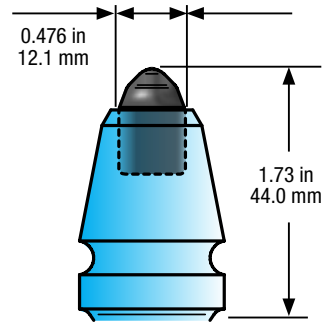

TC403L
Carbide Plug

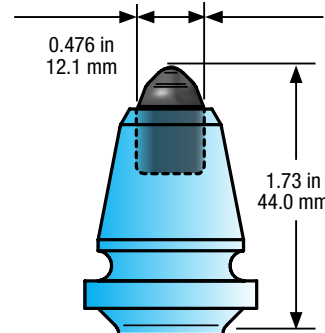

TC403
Carbide Plug

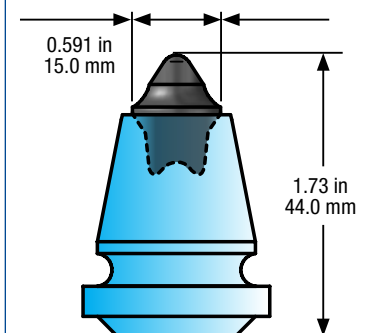

TC473
Carbide Hybrid
(Plug/Valve Seat)

Features:

- Standard body design
- Used for Core Barrels and Augers
- Puller groove for easy tool removal
- Offered with a Wedding Band or Sleeve retainer

Tool Part Number	Shank (in, mm)	Shoulder (in, mm)	Tip Diameter (in, mm)	Gauge (in, mm)	Pieces per Box	Pieces per Pallet
TC403L	0.74 in 19.0 mm	1.06 in 27.0 mm	0.476 in 12.1 mm	1.73 in 44.0 mm	65	3900
TC403	0.74 in 19.0 mm	1.25 in 31.75 mm	0.476 in 12.1 mm	1.73 in 44.0 mm	65	3900
TC473	0.74 in 19.0 mm	1.25 in 31.75 mm	0.591 in 15.0 mm	1.73 in 44.0 mm	65	3900

Block Part Number	Bore Hole Diameter (in, mm)	Width (in, mm)	Angle (degrees)	Internal Groove	Pieces per Box	Pieces per Pallet
B19L45	.782 in 19.87 mm	1.375 in 34.9 mm	45°	Yes	35	2100
B19H45	.782 in 19.87 mm	1.624 in 41.28 mm	45°	Yes	35	2100
B19HT45	.782 in 19.87 mm	1.654 in 42.0 mm	45°	Yes	20	900

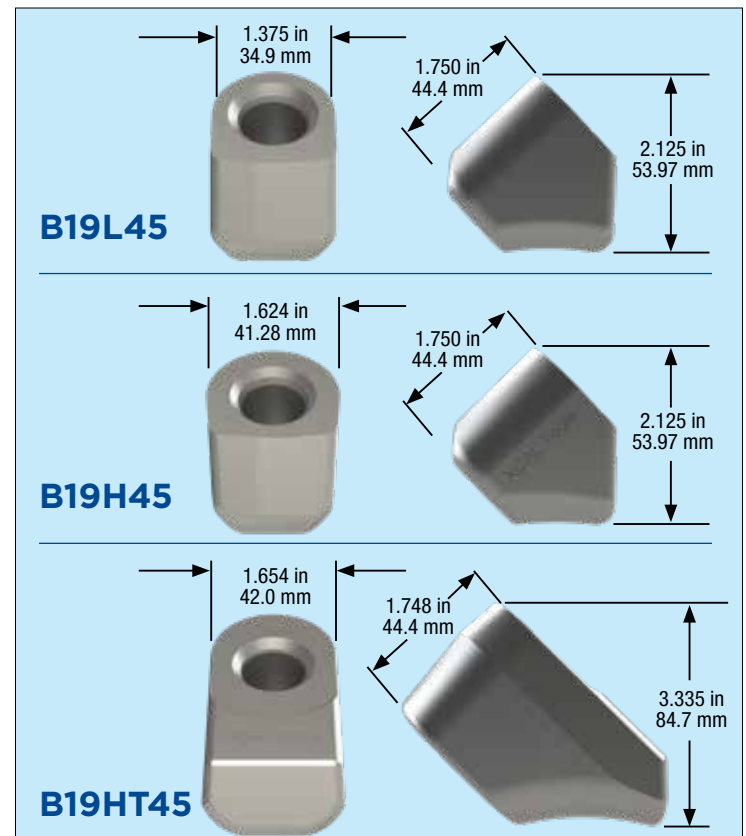

Proudly made in the U.S.A.

Drilling



Features:

- Bumped sleeve for improved retention
- Puller Groove to aid in extraction
- Interchangeable series offers flexibly

Tool Part Number	Shank (in, mm)	Shoulder (in, mm)	Tip Diameter (in, mm)	Gauge (in, mm)	Pieces per Box	Pieces per Pallet
TJ401	0.86 in 22.0 mm	1.5 in 38.1 mm	0.638 in 16.0 mm	1.73 in 44.0 mm	50	3000
TJ403	0.86 in 22.0 mm	1.5 in 38.1 mm	0.476 in 12.1 mm	1.73 in 44.0 mm	50	3000
TJ474	0.86 in 22.0 mm	1.5 in 38.1 mm	0.708 in 17.98 mm	1.73 in 44.0 mm	50	3000

Block Part Number	Bore Hole Diameter (in, mm)	Width (in, mm)	Angle (degrees)	Internal Groove	Pieces per Box	Pieces per Pallet
B22NR45	0.885 in 22.48 mm	1.512 in 38.4 mm	45°	Yes	35	2100
B22H45	0.885 in 22.48 mm	1.625 in 47.3 mm	45°	Yes	35	2100
B22HT45	0.885 in 22.48 mm	1.625 in 47.3 mm	45°	Yes	35	2100

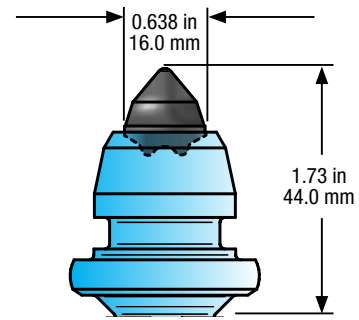

TJ401
Carbide Valve Seat Cap

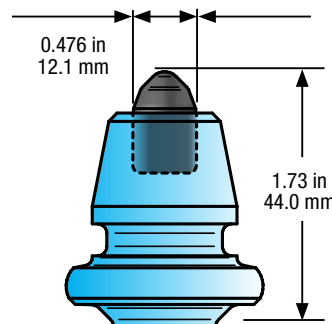

TJ403
Carbide Plug

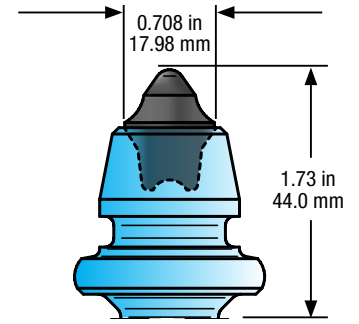

TJ474
Carbide Hybrid
(Plug/Valve Seat)

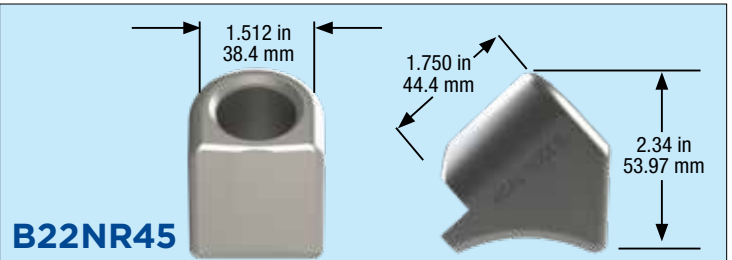

B22NR45

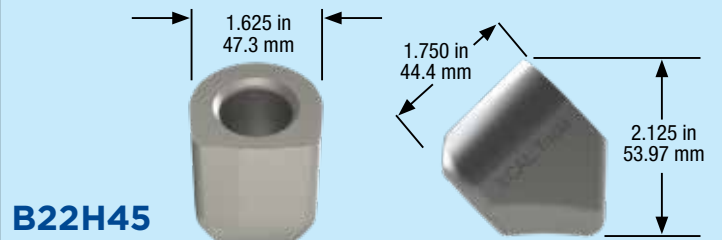

B22H45

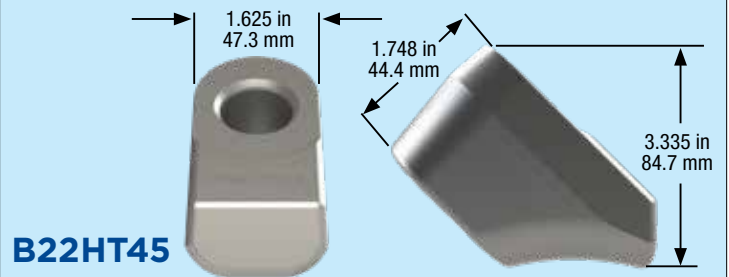

B22HT45



Proudly made in the U.S.A.

Drilling

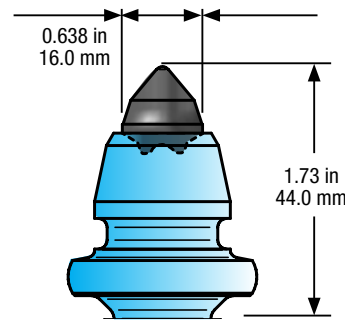

TJ401L
Carbide Valve Seat Cap

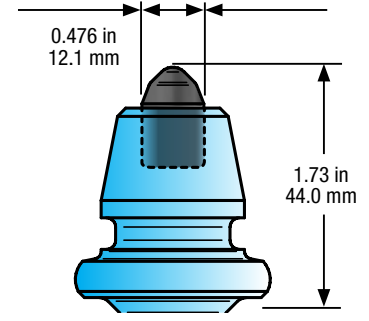

TJ403L
Carbide Plug

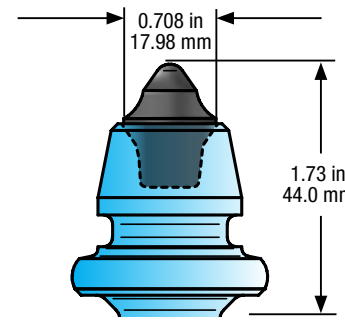

TJ474L
Carbide Hybrid
(Plug/Valve Seat)

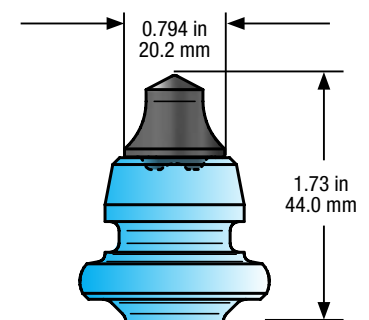

TJ486L
Carbide Valve Seat Cap

Features:

- Offered in a wide range of tips for impact and highly abrasive material
- Puller Groove to aid in extraction
- Interchangeable series offers flexibly

Tool Part Number	Shank (in, mm)	Shoulder (in, mm)	Tip Diameter (in, mm)	Gauge (in, mm)	Pieces per Box	Pieces per Pallet
TJ401L	0.86 in 22.0 mm	1.5 in 38.1 mm	0.638 in 16.0 mm	1.73 in 44.0 mm	50	3000
TJ403L	0.86 in 22.0 mm	1.5 in 38.1 mm	0.476 in 12.1 mm	1.73 in 44.0 mm	50	3000
TJ474L	0.86 in 22.0 mm	1.5 in 38.1 mm	0.708 in 17.98 mm	1.73 in 44.0 mm	50	3000
TJ486L	0.86 in 22.0 mm	1.5 in 38.1 mm	0.794 in 20.2 mm	1.73 in 44.0 mm	50	3000

Block Part Number	Bore Hole Diameter (in, mm)	Width (in, mm)	Angle (degrees)	Internal Groove	Pieces per Box	Pieces per Pallet
B22NR45	0.885 in 22.48 mm	1.512 in 38.4 mm	45°	Yes	35	2100
B22H45	0.885 in 22.48 mm	1.625 in 47.3 mm	45°	Yes	35	2100
B22HT45	0.885 in 22.48 mm	1.625 in 47.3 mm	45°	Yes	35	2100

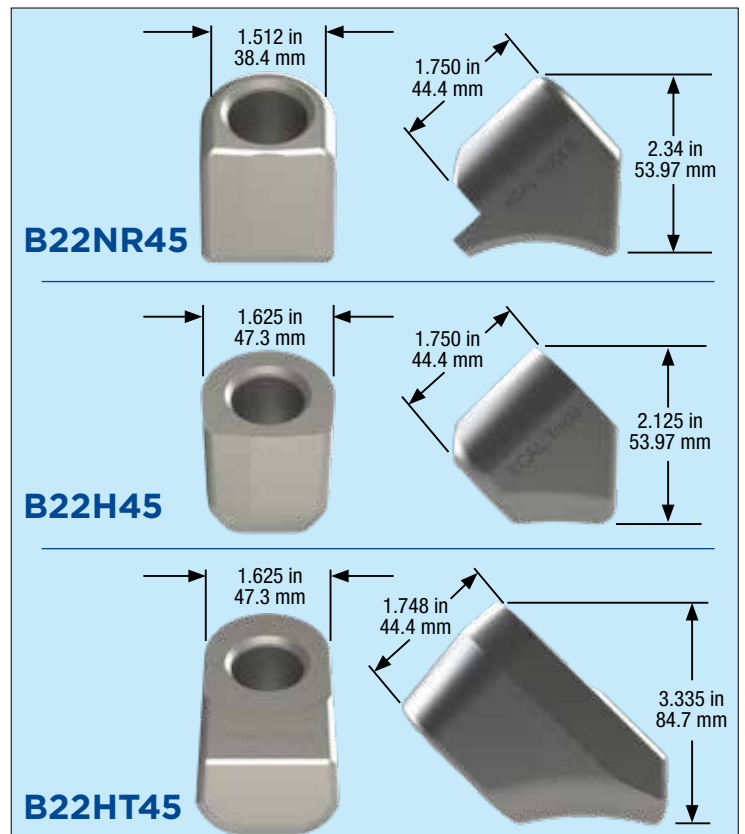

Proudly made in the U.S.A.

Drilling



Detailed view of carbide tip

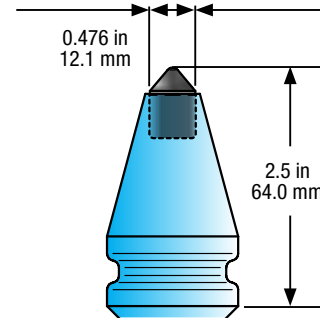

DR35
Carbide Plug

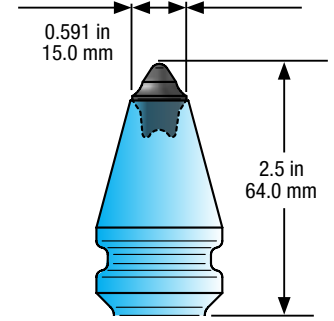

DR73
Carbide Hybrid
(Plug/Valve Seat)

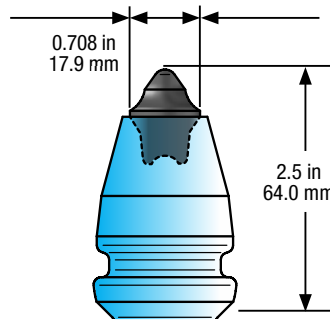

DR74
Carbide Hybrid
(Plug/Valve Seat)

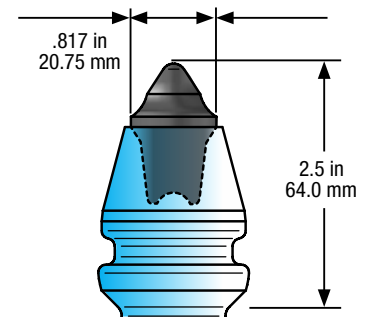

DR75
Carbide Hybrid
(Plug/Valve Seat)

Features:

- Sharp nose for increased penetration
- Offered in a Hybrid tip, or Plug tip for impact and highly abrasive material
- Interchangeable series offers flexibly

Tool Part Number	Shank (in, mm)	Shoulder (in, mm)	Tip Diameter (in, mm)	Gauge (in, mm)	Pieces per Box	Pieces per Pallet
DR35	1.0 in 25.0 mm	1.5 in 38.1 mm	0.476 in 12.1 mm	2.5 in 64.0 mm	35	2100
DR73	1.0 in 25.0 mm	1.5 in 38.1 mm	0.591 in 15.0 mm	2.5 in 64.0 mm	35	2100
DR74	1.0 in 25.0 mm	1.5 in 38.1 mm	0.708 in 17.9 mm	2.5 in 64.0 mm	35	2100
DR75	1.0 in 25.0 mm	1.5 in 38.1 mm	.817 in 20.75 mm	2.5 in 64.0 mm	35	2100

Block Part Number	Bore Hole Diameter (in, mm)	Width (in, mm)	Angle (degrees)	Internal Groove	Pieces per Box	Pieces per Pallet
B25HN45	1.012 in 25.71 mm	1.72 in 43.7 mm	45°	Yes	15	900
B25H45	1.012 in 25.71 mm	1.969 in 50.0 mm	45°	Yes	8	480

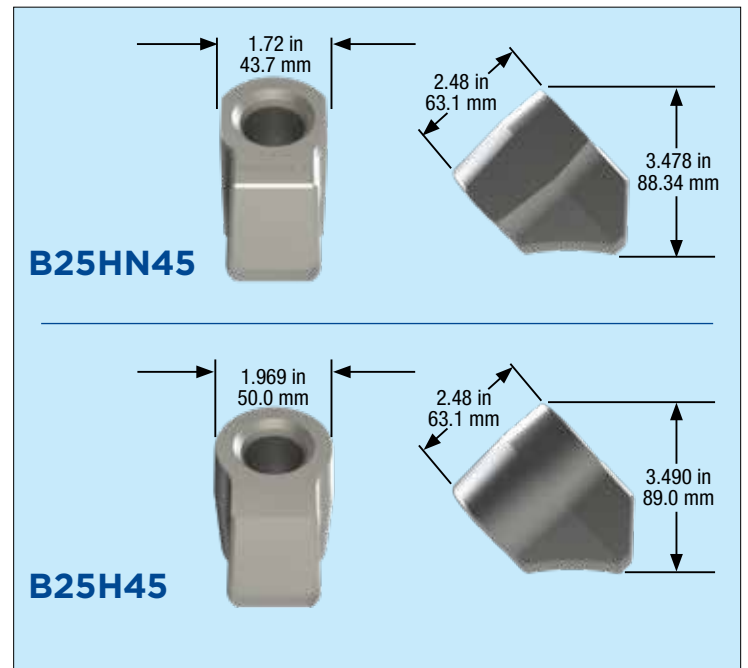

Proudly made in the U.S.A.

Drilling



Features:

- Wide-flare shoulder provides maximum block and bore protection
- Offered in a Hybrid tip or Wide-Top tip for impact and highly abrasive material
- Interchangeable series offers flexibility

Tool Part Number	Shank (in, mm)	Shoulder (in, mm)	Tip Diameter (in, mm)	Gauge (in, mm)	Pieces per Box	Pieces per Pallet
DRW73	1.0 in 25.0 mm	1.84 in 46.7 mm	0.591 in 15.0 mm	2.50 in 64.0 mm	30	1800
DRW74	1.0 in 25.0 mm	1.84 in 46.7 mm	.708 in 17.98 mm	2.50 in 64.0 mm	30	1800
DRW75	1.0 in 25.0 mm	1.84 in 46.7 mm	.817 in 20.75 mm	2.50 in 64.0 mm	30	1800
DRW76	1.0 in 25.0 mm	1.84 in 46.7 mm	0.930 in 23.62 mm	2.50 in 64.0 mm	30	1800

Block Part Number	Bore Hole Diameter (in, mm)	Width (in, mm)	Angle (degrees)	Internal Groove	Pieces per Box	Pieces per Pallet
B25HN45	1.012 in 25.71 mm	1.72 in 43.7 mm	45°	Yes	15	900
B25H45	1.012 in 25.71 mm	1.969 in 50.0 mm	45°	Yes	8	480

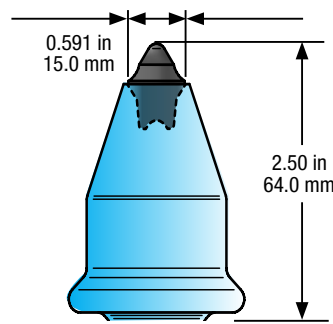

DRW73
Carbide Hybrid
(Plug/Valve Seat)

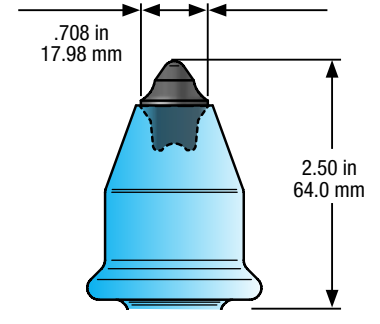

DRW74
Carbide Hybrid
(Plug/Valve Seat)

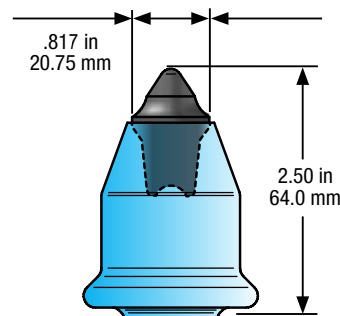

DRW75
Carbide Hybrid
(Plug/Valve Seat)

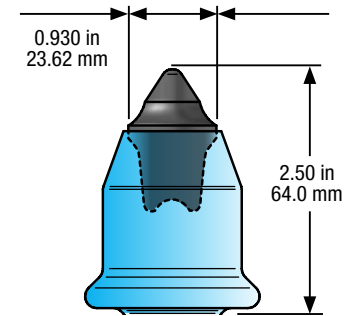

DRW76
Carbide Hybrid
(Plug/Valve Seat)

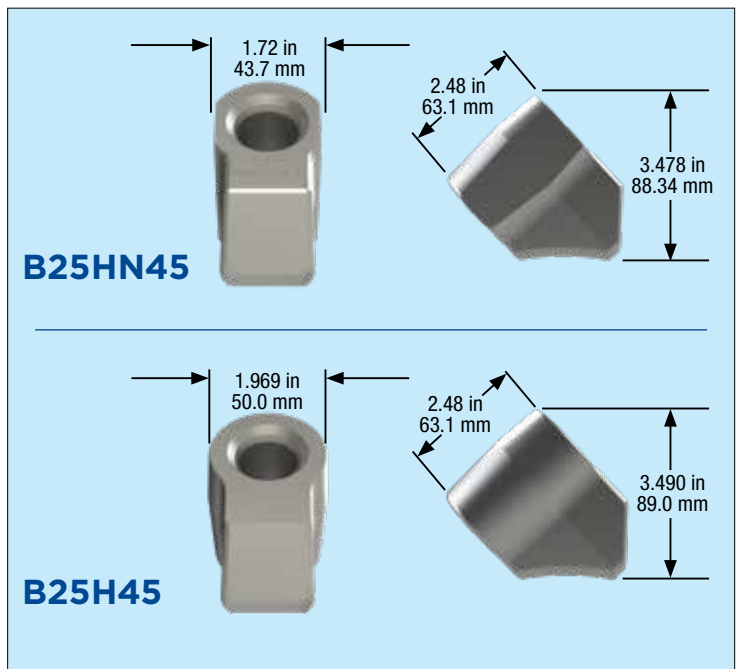

Proudly made in the U.S.A.

Drilling

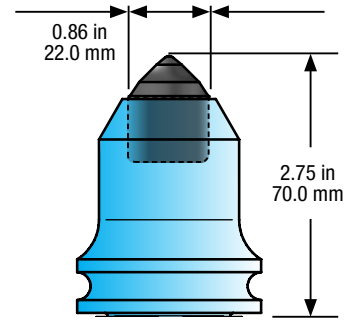

DX19
Carbide Plug

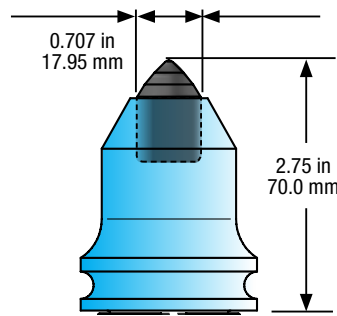

DX21
Carbide Plug

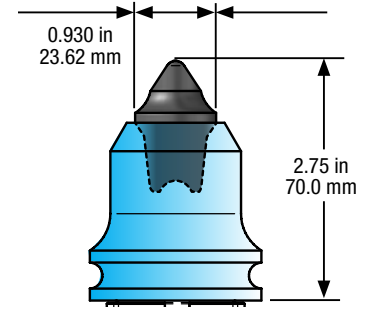

DX76
Carbide Hybrid

Features:

- Offered in Plugged tip, Hybrid tip and Large Cap tip for impact and highly abrasive material
- Offered with or without Puller groove for easy extraction
- Wide Shoulder tools offer maximum block, bore and seat protection

Tool Part Number	Shank (in, mm)	Shoulder (in, mm)	Tip Diameter (in, mm)	Gauge (in, mm)	Pieces per Box	Pieces per Pallet
DX19	1.5 in 30.0 mm	1.96 in 49.7 mm	0.86 in 22.0 mm	2.75 in 70.0 mm	10	600
DX21	1.5 in 30.0 mm	1.96 in 49.7 mm	0.707 in 17.95 mm	2.75 in 70.0 mm	10	600
DX76	1.5 in 30.0 mm	1.96 in 49.7 mm	0.930 in 23.62 mm	2.75 in 70.0 mm	10	600

Block Part Number	Bore Hole Diameter (in, mm)	Width (in, mm)	Angle (degrees)	Internal Groove	Pieces per Box	Pieces per Pallet
B38H45	1.50 in 38.2 mm	2.62 in 66.5 mm	45°	Yes	8	480
B38R	1.50 in 38.1 mm	2.99 in 76.0 mm	N/A	Yes	15	900

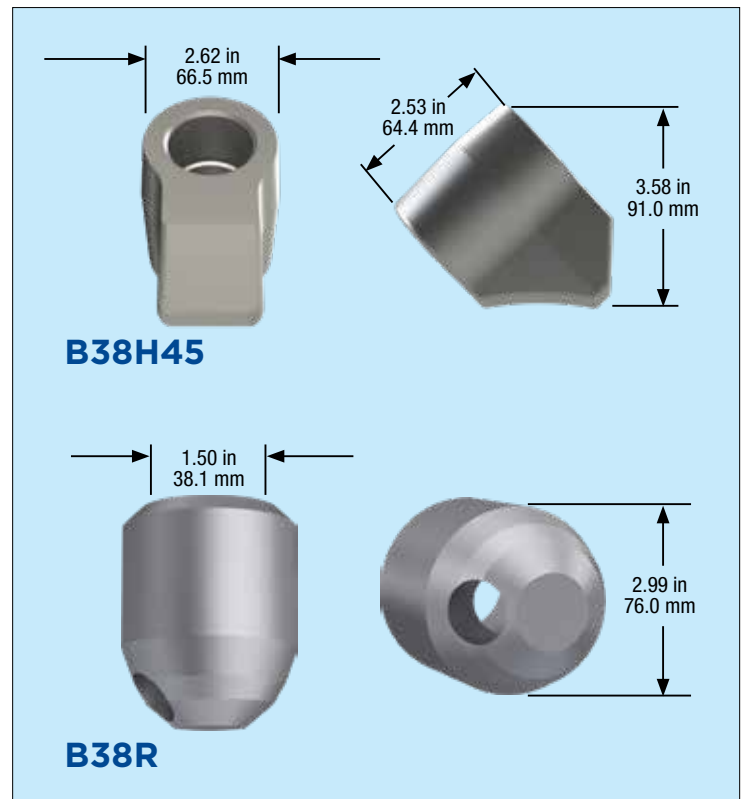

Proudly made in the U.S.A.

Drilling



Features:

- Offered in Plugged tip, Hybrid tip and Large Cap tip for impact and highly abrasive material
- Offered with or without Puller groove for easy extraction
- Wide Shoulder tools offer maximum block, bore and seat protection

Tool Part Number	Shank (in, mm)	Shoulder (in, mm)	Tip Diameter (in, mm)	Gauge (in, mm)	Pieces per Box	Pieces per Pallet
DXW20	1.5 in 30.0 mm	2.5 in 64.0 mm	1.30 in 33.02 mm	2.5 in 64.0 mm	10	600
DXW21	1.5 in 30.0 mm	2.5 in 64.0 mm	0.707 in 17.95 mm	2.75 in 70.0 mm	10	600
DXW76	1.5 in 30.0 mm	2.5 in 64.0 mm	0.817 in 20.75 mm	2.75 in 70.0 mm	10	600

Block Part Number	Bore Hole Diameter (in, mm)	Width (in, mm)	Angle (degrees)	Internal Groove	Pieces per Box	Pieces per Pallet
B38H45	1.50 in 38.2 mm	2.62 in 66.5 mm	45°	Yes	8	480
B38R	1.50 in 38.1 mm	2.99 in 76.0 mm	N/A	Yes	15	900

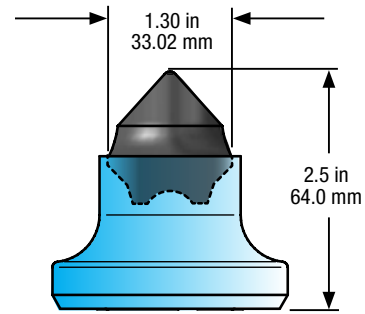

DXW20
Valve Seat

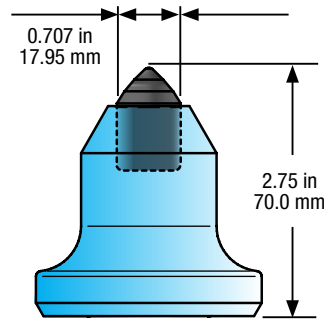

DXW21
Carbide Plug

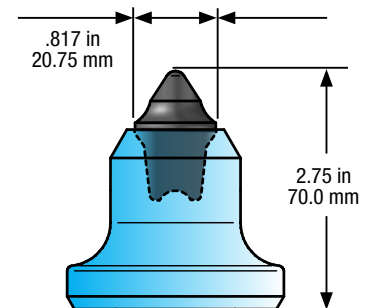

DXW76
Carbide Hybrid
(Plug/Valve Seat)

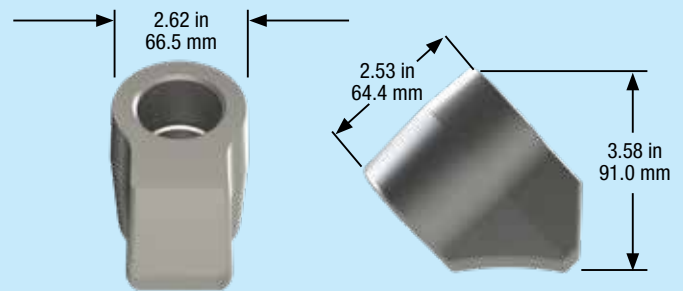

B38H45

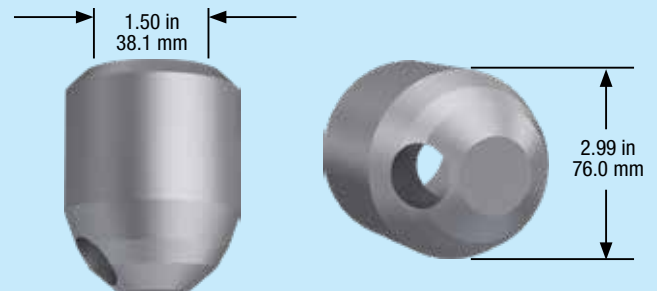

B38R



Proudly made in the U.S.A.

Drilling

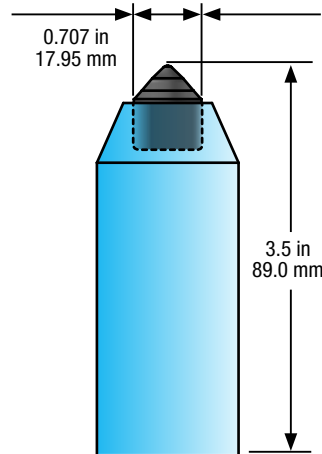

DXL08K
Carbide Plug

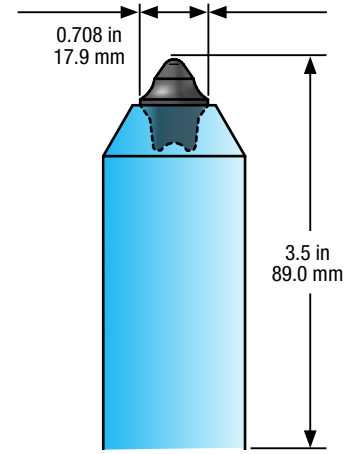

DXL74K
Carbide Hybrid
(Plug/Valve Seat)

Features:

- Unique tool design provides superior penetration
- Offered in both Plugged tip or Hybrid tip for impact and highly abrasive material
- Utilizes Sleeve and/or Snap ring retainer to maintain maximum block bore and seat protection
- Offered with or without Puller groove for easy extraction

Tool Part Number	Shank (in, mm)	Shoulder (in, mm)	Tip Diameter (in, mm)	Gauge (in, mm)	Pieces per Box	Pieces per Pallet
DXL08K	1.5 in 30.0 mm	NA	0.707 in 17.95 mm	3.5 in 89.0 mm	10	600
DXL74K	1.5 in 30.0 mm	NA	0.708 in 17.9 mm	3.5 in 89.0 mm	10	600

Block Part Number	Bore Hole Diameter (in, mm)	Width (in, mm)	Angle (degrees)	Internal Groove	Pieces per Box	Pieces per Pallet
B38H45	1.50 in 38.2 mm	2.62 in 66.5 mm	45°	Yes	8	480
B38R	1.50 in 38.1 mm	2.99 in 76.0 mm	N/A	Yes	15	900

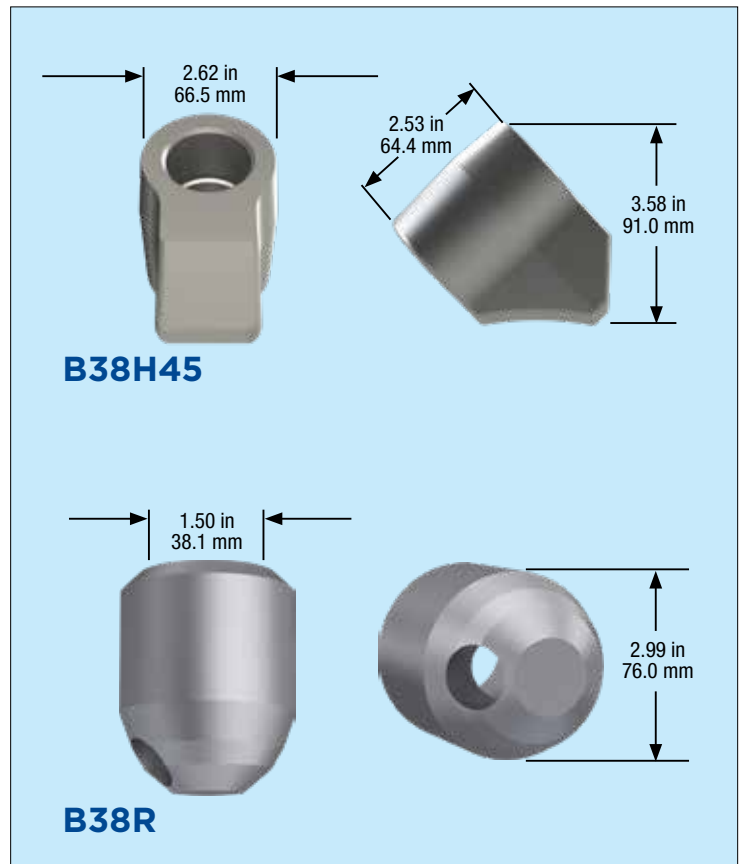

B38H45

B38R



Proudly made in the U.S.A.

Drilling



Features:

- Protruding nose for better penetration
- For use on Core Barrel and Casing Shoes

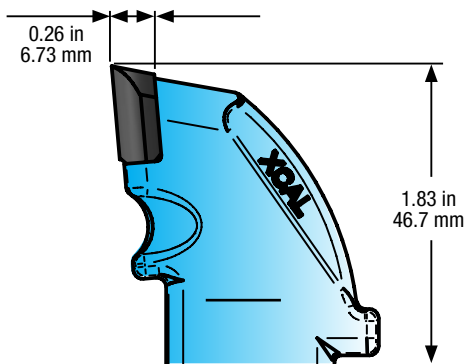

XJL7
Carbide Radial
(Plug/Valve Seat)

Tool Part Number	Shank (in, mm)	Tip Diameter (in, mm)	Gauge (in, mm)	Pieces per Box	Pieces per Pallet
XJL7	1.80 in 45.0 mm	0.26 in 6.7 mm	1.83 in 46.7 mm	60	3600



Proudly made in the U.S.A.

Accessories



Curved Knock Out Punch

- Tool remover with carbide tip for extended life

Part Number Product Code	CKP
------------------------------------	-----



Installation Remover

- For removal of c-clip

Part Number Product Code(s)	CC25, CC30
---------------------------------------	------------



Forked Puller

- For removal of tools

Part Number Product Code(s)	FP19, FP22, FP25
---------------------------------------	------------------



Wedge Puller

- For removal of shank tools with collars

Part Number Product Code	W25
------------------------------------	-----

Wedge Puller

- For removal of step shank tools with collars

Part Number Product Code	W38
------------------------------------	-----



Snap Ring Pliers

- For removal of snap rings

Part Number Product Code	SRP86/Ratchet Snap Ring Pliers
------------------------------------	--------------------------------





**AS PART OF THE XCAL TOOLS COMPANY,
TAMCO PROUDLY OFFERS A FULL LINE OF AIR
AND PNEUMATIC CONSTRUCTION TOOLS.**

**SCAN
QR CODE
FOR THE FULL
CATALOG**



Air Tool Accessories



Whip Hoses

Part Number	Description
WH5-3/8	5' Whip Hose - 3/8" NPT Swivel End, rated 250 PSI
WH5-7/8	5' Whip Hose - 7/8" x 24" Thread/In Swivel End, rated 250 PSI
WH5-1/2	5' Whip Hose - 1/2" ID, 1/2" Bent Swivel, rated 250 PSI
WH10-3/8	10' Whip Hose - 3/8" NPT Thread/In Swivel End, rated 250 PSI
WH10-1/2	10' Whip Hose - 1/2" NPT Swivel End, rated 250 PSI
WH10-7/8	10' Whip Hose - 7/8" X 24" Thread/In Swivel End, rated 250 PSI
AH50	50' Air Hose - 3/4" Hose w/Universal Fittings, rated 300 PSI

Whip Hoses with Oilers

Part Number	Description
WH6-1/2OILS	Whip Hose 1/2" x 6' with 1/2" Swivel and Inline Oiler
WH6-3/8OILS	Whip Hose 1/2" x 6' with 3/8" Swivel and Inline Oiler
WH6-7/8OILS	Whip Hose 1/2" x 6' with 7/8" Swivel and Inline Oiler
WH8-CPOILS	Whip Hose 3/4" x 8' with Universal Fittings and Inline Oiler



Hydraulic Hoses

Part Number	Description
HYD6-3/8	Whip Hose 1/2" x 6' with 3/8" Swivel
HYD6-1/2	Whip Hose 1/2" x 6' with 1/2" Swivel
HYD6-7/8	Whip Hose 1/2" x 6' with 7/8" Swivel

In-Line Oilers

Part Number	Description
OL	In-Line Oiler 1.4 Fluid Oz.
1L	In-Line Oiler 3.7 Fluid Oz.
2L	In-Line Oiler 11.0 Fluid Oz.
3L	In-Line Oiler 16.0 Fluid Oz.
430101VOJ	L0-15 Clearview In-Line Oiler 6.0 Fluid Oz.



Proudly made in the U.S.A.





AS PART OF THE XCAL TOOLS COMPANY, TAMCO PROUDLY OFFERS A

Manifolds

Eliminate clutter and run just one hose to your worksite! Connect from four to eight pneumatic tools at once. Equipped with a gauge to monitor pressure. All models are stackable!!



Part Number	Outlets	Capacity	Working Pressure	Test Pressure	Inlet Size	Tank Dia.	Weight
5G	4	5 gallon	200 PSI	300 PSI	1"	10"	36 lbs.
15G	8	15 gallon	200 PSI	300 PSI	2"	12"	72 lbs.

Whip Checks

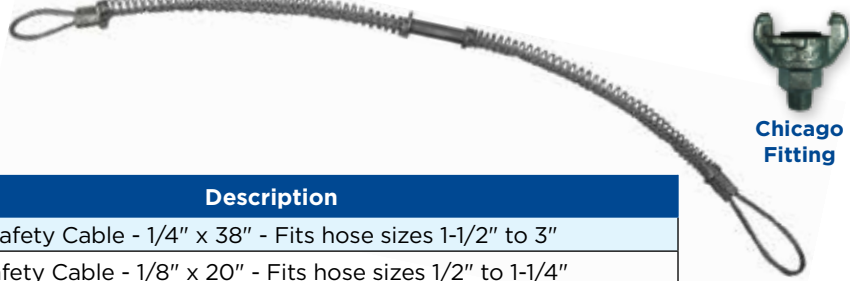

Part Number	Description
WA2	Safety Cable - 1/4" x 38" - Fits hose sizes 1-1/2" to 3"
WB1	Safety Cable - 1/8" x 20" - Fits hose sizes 1/2" to 1-1/4"



All Weather!

Useable down to temperatures of -30° F

Air Tool Oil

Part Number	Description
ATOGL	Air Tool Oil - One Gallon

LOOKING FOR MORE OPTIONS?

Reach out to your regional sales representative to receive a quote and check availability for the parts you are interested in.

You can contact us via email at info.bristol@xcaltools.com or by calling us at (276) 644-3520.



Proudly made in the U.S.A.





Threaded Rock Bits

Multi-Use Threaded Carbide Rock Bits

Bit Diameter Inch	Bit Diameter MM	Part Number	Wt./Lb.	Carbide Height (MM)	Carbide Width (MM)
1-3/8"	35	HTI-137H	0.50	14	8
1-1/2"	38	HTI-150H	0.60	14	8
1-5/8"	41	HTI-162H	0.65	14	8
1-3/4"	45	HTI-175H	0.80	14	8
1-7/8"	48	HTI-187H	0.90	14	8
2"	51	HTI-200H	1.10	14	8
2-1/4"	57	HTI-225H	1.20	14	8
2-1/2"	64	HTI-250H	1.30	14	9.5
2-3/4"	70	HTI-275H	1.55	20	12
3"	76	HTI-300H	3.00	23	12
3-1/2"	89	HTI-350H	3.00	16	12
4"	101	HTI-400H	3.65	16	12



Rebar Cutter Bits H-Thread

Bit Diameter Inch	Part Number
1-3/8"	HTI-137HRB
1-1/2"	HTI-150HRB
1-5/8"	HTI-162HRB
1-3/4"	HTI-175HRB
1-7/8"	HTI-187HRB
2"	HTI-200HRB
2-1/4"	HTI-225HRB
2-1/2"	HTI-250HRB



7/8" x 3-1/4" Shank H-Thread

Length U.C.	Part Number	Wt./Lb.
12"	H7312	3.00
18"	H7318	4.00
24"	H7324	5.00
30"	H7330	6.00
36"	H7336	7.00
48"	H7348	9.00
60"	H7360	11.00
72"	H7372	14.00
96"	H7396	18.00
120"	H73120	22.00



7/8" x 4-1/4" Shank H-Thread

Length U.C.	Part Number	Wt./Lb.
12"	H7412	3.25
18"	H7418	4.25
24"	H7424	5.25
30"	H7430	6.25
36"	H7436	7.25
48"	H7448	9.25
60"	H7460	12.00
72"	H7472	13.25

1" x 4-1/4" Shank H-Thread

Length U.C.	Part Number	Wt./Lb.
12"	H1412	4.00
18"	H1418	5.00
24"	H1424	7.00
30"	H1430	9.00
36"	H1436	10.00
48"	H1448	12.00
60"	H1460	15.00
72"	H1472	18.00
96"	H1496	23.00
120"	H14120	28.00

H-Thread Extensions

Length U.C.	Part Number	Wt./Lb.
24"	H24X	7.00
36"	H36X	10.00
48"	H48X	12.00
72"	H72X	18.00
96"	H96X	23.00





15020 INDUSTRIAL PARK ROAD
BRISTOL, VA USA
(276) 644-3520

www.xcaltools.com

