

# Drilling

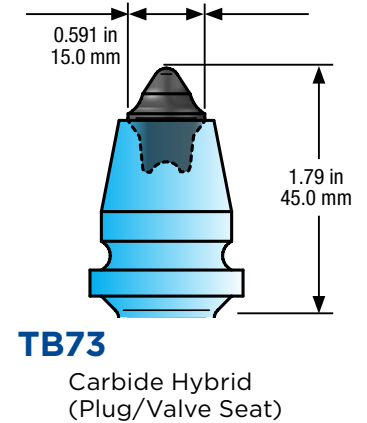
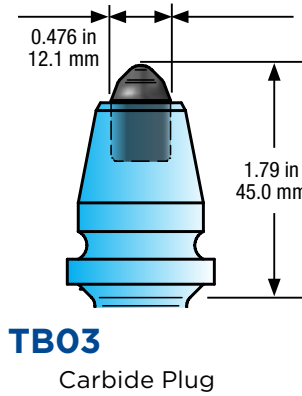
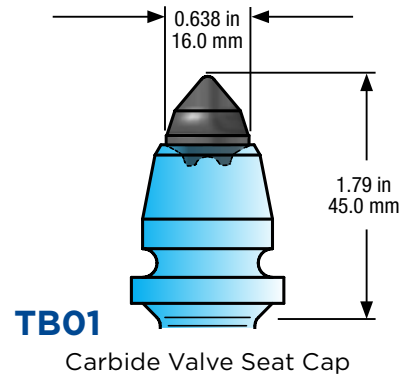

## Features:

- Standard body design
- Used for Core Barrels and Augers
- Puller groove for easy tool removal
- Interchangeable series offers flexibility

| Tool Part Number | Shank (in, mm)     | Shoulder (in, mm) | Tip Diameter (in, mm) | Gauge (in, mm)     | Pieces per Box | Pieces per Pallet |
|------------------|--------------------|-------------------|-----------------------|--------------------|----------------|-------------------|
| TB01             | 0.72 in<br>18.0 mm | 1.0 in<br>25.4 mm | 0.638 in<br>16.0 mm   | 1.79 in<br>45.0 mm | 65             | 3900              |
| TB03             | 0.72 in<br>18.0 mm | 1.0 in<br>25.4 mm | 0.476 in<br>12.1 mm   | 1.79 in<br>45.0 mm | 65             | 3900              |
| TB73             | 0.72 in<br>18.0 mm | 1.0 in<br>25.4 mm | 0.591 in<br>15.0 mm   | 1.79 in<br>45.0 mm | 65             | 3900              |

| Block Part Number | Bore Hole Diameter (in, mm) | Width (in, mm)       | Angle (degrees) | Internal Groove | Pieces per Box | Pieces per Pallet |
|-------------------|-----------------------------|----------------------|-----------------|-----------------|----------------|-------------------|
| B18L45            | .750 in<br>19.05 mm         | 1.375 in<br>34.9 mm  | 45°             | Yes             | 35             | 2100              |
| B18H45            | .750 in<br>19.05 mm         | 1.625 in<br>41.28 mm | 45°             | Yes             | 35             | 2100              |
| B18HT45           | .750 in<br>19.05 mm         | 1.654 in<br>42.0 mm  | 45°             | Yes             | 20             | 900               |

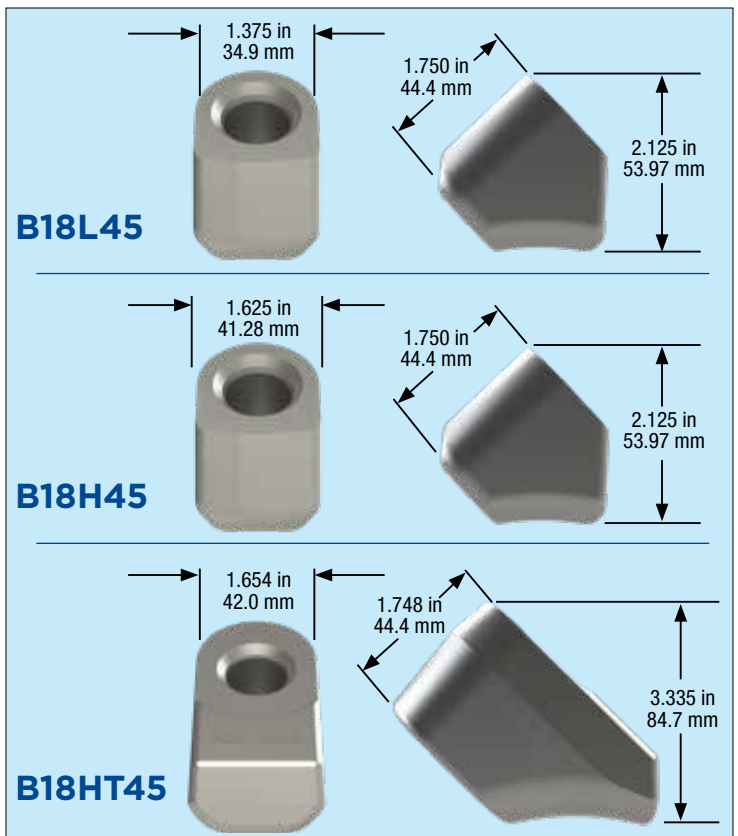

Proudly made in the U.S.A.