

35 mm Grading System

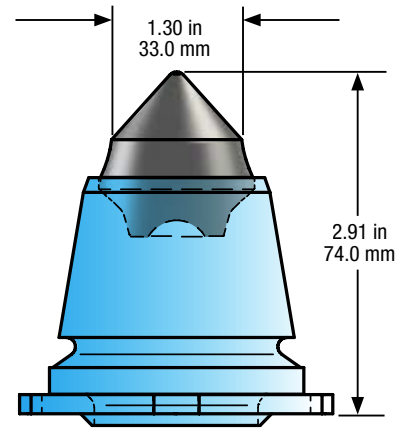

GW3520
Valve-Seat Carbide Tip

Features:

- Heavy Duty Body
- Square washer enhances tool rotation
- Serves as a replaceable “armor plate” wear surface

Part Number	Shank (in, mm)	Tip Diameter (in, mm)	Base Diameter (in, mm)	Gauge (in, mm)	Pieces per Box	Pieces per Pallet
GW3520	1.37 in 35.0 mm	0.68 in 17.3 mm	1.30 in 33.0 mm	2.91 in 74.0 mm	8	480

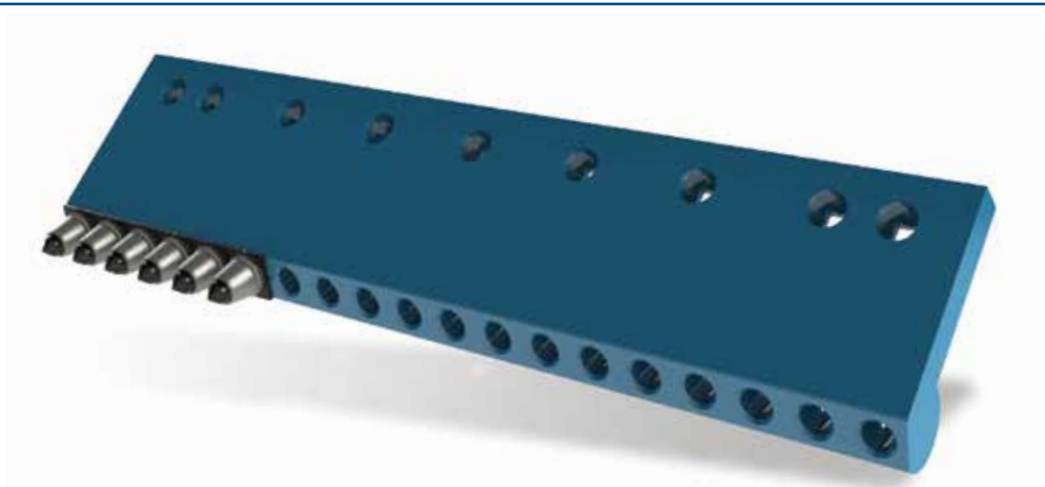

Part Number	Length (ft, m)	Bolt Size (in, mm)	Tool Capacity
GB3548	4 ft 1.219 m	1 in 25.4 mm	19

Features:

- Tool spacing is 2.50"/63.5mm
- Multi-piece assembly allows for manageable installation
- Board fits bit GW3520



Proudly made in the U.S.A.

