

Trenching

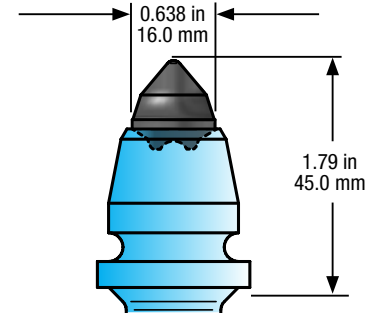

Detailed view of carbide tip



TB01
Carbide Valve Seat Cap

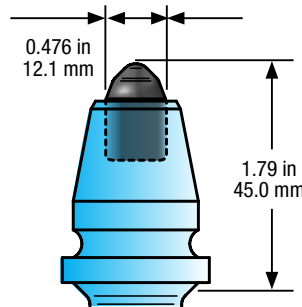

TB03
Carbide Plug

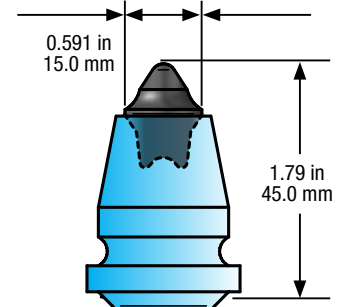

TB73
Carbide Hybrid
(Plug/Valve Seat)

Features:

- Standard body design
- Used for small Chain Trenchers and Rock Wheels
- Puller groove for easy tool removal
- Interchangeable series offers flexibility

Tool Part Number	Shank (in, mm)	Shoulder (in, mm)	Tip Diameter (in, mm)	Gauge (in, mm)	Pieces per Box	Pieces per Pallet
TB01	0.72 in 18.0 mm	1.0 in 25.4 mm	0.638 in 16.0 mm	1.79 in 45.0 mm	65	3900
TB03	0.72 in 18.0 mm	1.0 in 25.4 mm	0.476 in 12.1 mm	1.79 in 45.0 mm	65	3900
TB73	0.72 in 18.0 mm	1.0 in 25.4 mm	0.591 in 15.0 mm	1.79 in 45.0 mm	65	3900

Block Part Number	Bore Hole Diameter (in, mm)	Width (in, mm)	Angle (degrees)	Internal Groove	Pieces per Box	Pieces per Pallet
B18L45	.750 in 19.05 mm	1.375 in 34.9 mm	45°	Yes	35	2100
B18H45	.750 in 19.05 mm	1.625 in 41.28 mm	45°	Yes	35	2100
B18HT45	.750 in 19.05 mm	1.654 in 42.0 mm	45°	Yes	20	900

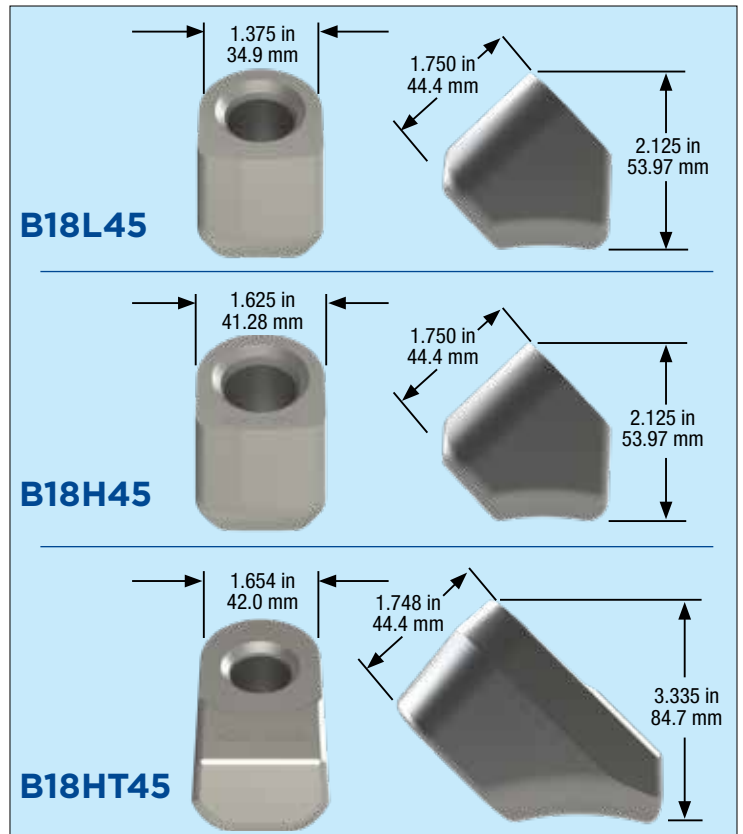

Proudly made in the U.S.A.